

CALCULATING THE FIRE RESISTANCE OF EXPOSED WOOD MEMBERS

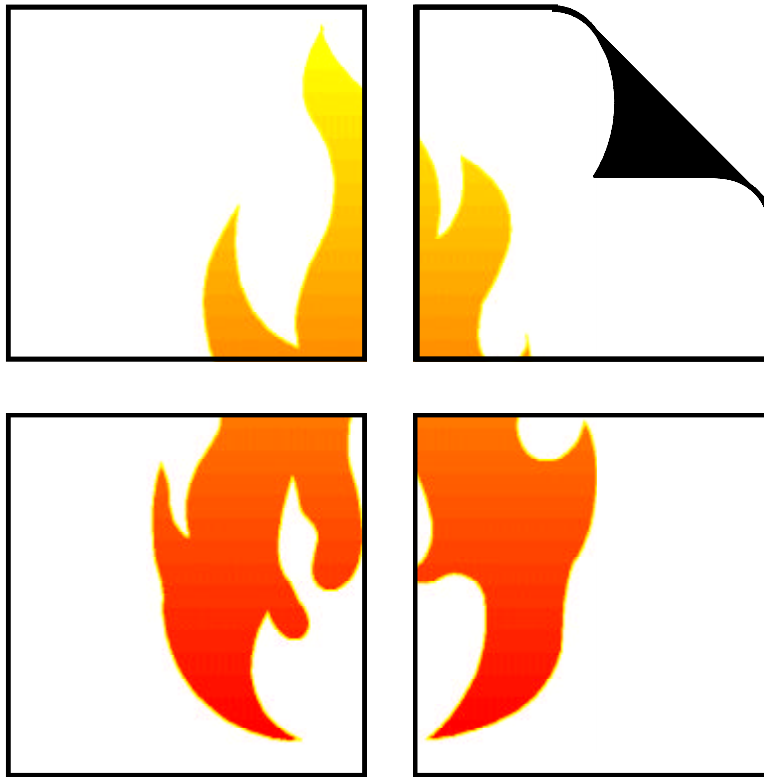

TECHNICAL REPORT 10

The American Wood Council (AWC) is the wood products division of the American Forest & Paper Association (AF&PA). AF&PA is the national trade association of the forest, paper and wood products industry, representing member companies engaged in growing, harvesting and processing wood and wood fiber, manufacturing pulp, paper and paperboard products from both virgin and recycled fiber, and producing engineered and traditional wood products. For more information see www.afandpa.org.

While every effort has been made to insure the accuracy of the information presented, and special effort has been made to assure that the information reflects the state-of-the-art, neither the American Forest & Paper Association nor its members assume any responsibility for any particular design prepared from this publication. Those using this document assume all liability from its use.

Copyright © 2003
American Forest & Paper Association, Inc.

American Wood Council
1111 19th St., NW, Suite 800
Washington, DC 20036
202-463-4713
awcinfo@afandpa.org
www.awc.org

TABLE OF CONTENTS

	<u>Page</u>
Table of Contents	i
List of Figures	ii
List of Tables	ii
Nomenclature	iv

Part I: Development of Design Procedures for Exposed Wood Members

1.1 Introduction	1
1.2 Concepts of Heavy Timber Fire Design	1
1.3 Background	2
1.4 New Mechanics-Based Design Method	5

Part II: Comparison Between Calculation Methods and Experiments

2.1 General	9
2.2 Beams	9
2.3 Columns	12
2.4 Tension Members	19
2.5 Decking	21
2.6 Summary	23

Part III: Design Procedures for Exposed Wood Members

3.1 Design Procedures for Wood Members	25
3.2 Design Procedures for Timber Decks	26
3.3 Special Provisions for Glued Laminated Timber Beams	27
3.4 Wood Connections	27
3.5 Application Guidelines for Wood Members	27
Beam Design Example	30
Column Design Example	31
Tension Member Design Example	33
Deck Design Example	34

References	35
-------------------------	-----------

Appendix: Design Aids	37
------------------------------------	-----------

LIST OF FIGURES

	<u>Page</u>
Figure 1 Beam exposed from 3 sides	1
Figure 2 Symbols for cross-sectional dimensions	2
Figure 3 Comparison of Predicted to Observed Time (Wood beams exposed on three sides)	12
Figure 4 Comparison of Predicted to Observed Time (Wood columns exposed on four sides)	19
Figure 5 Comparison of Predicted to Observed Time (Tension members exposed on four sides)	20
Figure 6 Comparison of Predicted to Observed Time (Timber decks exposed on bottom side)	22
Figure 7 Beam to Column Connection (Not Exposed to Fire)	28
Figure 8 Beam to Column Connection (Exposed to Fire - where appearance is a factor)	28
Figure 9 Ceiling Construction	28
Figure 10 Beam to Column Connection (Exposed to Fire - where appearance is not a factor) ..	28
Figure 11 Column Connection (Covered)	29
Figure 12 Beam to Girder Connection (Concealed connection)	29

LIST OF TABLES

	<u>Page</u>
Table 1.4.1 Cross-Sectional Properties for Four-Sided Exposure	6
Table 1.4.2 Allowable Design Stress to Average Ultimate Strength Adjustment Factors	7
Table 2.2a Beams Tested	11
Table 2.2b Measured and Calculated Beam Fire Resistance Times	11
Table 2.3a Columns tested in France	13
Table 2.3b Columns tested in Germany by Stanke et al.	14
Table 2.3c Columns tested in England by Malhotra et al.	16

Table 2.3d Measured and Calculated Column Fire Resistance Times 17

Table 2.4a Tension Members Tested 20

Table 2.4b Measured and Calculated Tension Member Fire Resistance Times 20

Table 2.5 Measured and Calculated Decking Fire Resistance Times 22

Table 3.1.1 Effective Char Rates and Char Layer Thickness for $\beta_n=1.5$ inches/hour 25

Table 3.1.2 Allowable Design Stress to Average Ultimate Strength Adjustment Factors, K ... 26

Appendix

Table 1 Design Stress Ratios For Timber Beams Exposed on Three-Sides 40

Table 2 Design Stress Ratios For Timber Beams Exposed on Four-Sides 41

Table 3 Design Stress Ratios For Timber Columns Exposed on Three-Sides
(Protected Surface in Depth Direction) 42

Table 4 Design Stress Ratios For Timber Columns Exposed on Three-Sides
(Protected Surface in Width Direction) 43

Table 5 Design Stress Ratios For Timber Columns Exposed on Four-Sides 44

Table 6 Design Stress Ratios For Timber Tension Members Exposed on Three-Sides
(Protected Surface in Depth Direction) 45

Table 7 Design Stress Ratios For Timber Tension Members Exposed on Three-Sides
(Protected Surface in Width Direction) 46

Table 8 Design Stress Ratios For Timber Tension Members Exposed on Four-Sides 47

Table 9 Design Stress Ratios For Exposed Timber Decks (T&G Joints) 48

Table 10 Design Stress Ratios For Exposed Timber Decks (Butt-Joints) 48

NOMENCLATURE

A	= area of section
a_{char}	= effective char layer thickness
B	= original section breadth
b	= breadth of remaining section
C_p	= column stability factor
c	= column stability constant, equal to 0.8 for sawn lumber and 0.9 for glulam
COV	= estimated coefficient of variation of statistical strength distributions
D	= original section depth
d	= depth of remaining section
E	= modulus of elasticity
F_b	= nominal allowable bending stress
F_c	= nominal allowable compression stress parallel to the grain
F_{cE}	= nominal allowable Euler buckling stress
F_t	= nominal allowable tension stress
I	= moment of inertia
K_{cE}	= constant in Euler buckling strength equation, 0.3 for sawn lumber; 0.418 for glulam
K_e	= column effective length factor to account for end conditions
K	= ratio of average ultimate strength to nominal allowable design stress
l	= column length
l_e	= column effective length
n	= number of repeat column tests
R	= ratio of applied to design load
R_{ASD}	= nominal allowable design capacity
S	= section modulus
t	= time (min)
Z	= load factor (--)
<i>Greek</i>	
β_n	= nominal char rate, linear char rate based on 1-hour exposure
β_{eff}	= effective char rate, adjusted for exposure time, t

Part I: Development of Design Procedures for Exposed Wood Members

1.1 INTRODUCTION

Large wood members have long been recognized for their ability to maintain structural integrity while exposed to fire. Early mill construction from the 19th century utilized massive timbers to carry large loads and to resist structural failure from fire. Exposed wood structural members are popular with architects and designers of modern buildings because they have a pleasing appearance, are economical and easy to use, while providing necessary fire endurance. Glued laminated (glulam) members are now commonly used where large sections and long spans are needed. Glulam members are composed of smaller laminates that are glued together. The small-section laminates are readily available. Glulam members offer the same fire performance advantages as large solid sawn members. Extensive research has demonstrated that synthetic glues used in the manufacture of glulam do not adversely affect fire performance [1].

The superior fire performance of heavy timbers can be attributed to the charring effect of wood. As wood members are exposed to fire, an insulating char layer is formed that protects the core of the section. Thus, beams and columns can be designed so that a sufficient cross section of wood remains to sustain the design loads for the required duration of fire exposure. A standard fire exposure is used for design purposes. In North America, this exposure is described in the standard fire endurance test ASTM E 119 [2]. Many other countries use a comparable test exposure found in ISO 834 [3]. In spite of the differences between standard fire endurance tests, experimental charring rates measured in various parts of the world appear to be consistent. This justifies the use of such data for design, regardless of origin.

1.2 CONCEPTS OF HEAVY TIMBER FIRE DESIGN

At fire exposure time t , the initial breadth, B , and depth, D , of a member are reduced to b and d , respectively. This is illustrated in Figure 1 for a section of a beam exposed on three sides. The original section is rectangular. However, since the corners are subject to heat transfer from two directions, charring is faster at these corners. This has a rounding effect, and shortly after ignition the remaining cross section is no longer rectangular. The boundary between the char layer and the remaining wood section is quite distinct, and corresponds to a temperature of approximately 550°F. The remaining wood section is heated over a narrow region that extends approximately 1.5" from the char front. The inner core of the remaining wood section is at ambient (or initial) temperature. A section smaller than the original section is capable of supporting the design load, because of the margin of safety provided in cold design. The original section is stressed only to a fraction of the maximum capacity. Failure occurs when the remaining cross section is stressed beyond the maximum capacity.

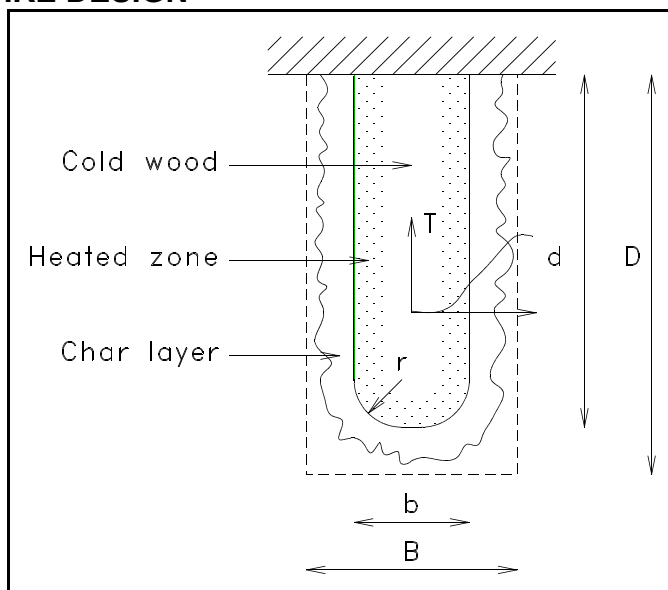

Figure 1. Wood member exposed from 3 sides

For members stressed in bending during fire exposure, failure occurs when the maximum bending capacity is exceeded due to the reduction in section modulus, S . For members stressed in tension parallel-to-grain during fire exposure, failure occurs when the maximum tension capacity is exceeded due to the reduction in cross-sectional area, A .

For members stressed in compression parallel-to-grain during fire exposure, the failure mode is a function of the column slenderness ratio, (L_e/D) . The column slenderness ratio changes with exposure time. For short column members ($L_e/D \approx 0$) stressed in compression during fire exposure, failure occurs when maximum compressive capacity is exceeded due to the reduction in cross-sectional area, A . For long column members ($L_e/D \approx \infty$) stressed in compression during fire exposure, failure occurs when critical buckling capacity is exceeded due to the reduction in the moment of inertia, I . Current code-accepted design procedures in the *1997 National Design Specification® for Wood Construction (NDS®)* and the *1996 Standard for Load and Resistance Factor Design (LRFD) for Engineered Wood Construction* contain a single column equation which is used to calculate a stability factor, C_p , which approximates the column capacity for all slenderness ratios based on the calculated interaction of theoretical short and long column capacities [9][25].

1.3 BACKGROUND

The current building code-accepted design method for fire-resistive exposed wood members used in North America is based on analysis conducted by T.T. Lie at the National Research Council of Canada in the 1970's [4]. The method was first recognized by the U.S. model building codes in 1984 through a National Evaluation Report [5]. In subsequent years, the method was adopted by the three model code organizations, allowing engineers and architects to include fire-rated heavy timber members in their projects without conducting expensive standard fire resistance tests.

Lie assumed a charring rate of 1.42 in/hr, and accounted for a reduction in strength and stiffness due to heating of a small zone progressing over approximately 1.5 in. ahead of the char front. Lie reported that studies have shown that the ultimate strength and stiffness of various woods, at temperatures that the uncharred wood normally reaches in fires, reduces to about 0.85-0.90 of the original strength and stiffness. To account for this effect, reductions to strength and stiffness properties were implemented by uniformly reducing strength and stiffness values over the remaining cross section by a factor α . Furthermore, a factor k was introduced to account for the ratio of design strength to ultimate strength. To obtain conservative estimates, Lie recommended a k factor of 0.33 based on a safety factor of 3, and an α factor of 0.8 to account for a strength and stiffness reduction.

Lie ignored increased rate of charring at the corners, and assumed that the remaining section is rectangular. With this assumption, initial breadth B and depth D of a member after t minutes of fire exposure are reduced to b and d respectively, as shown in Figure 2. Both b

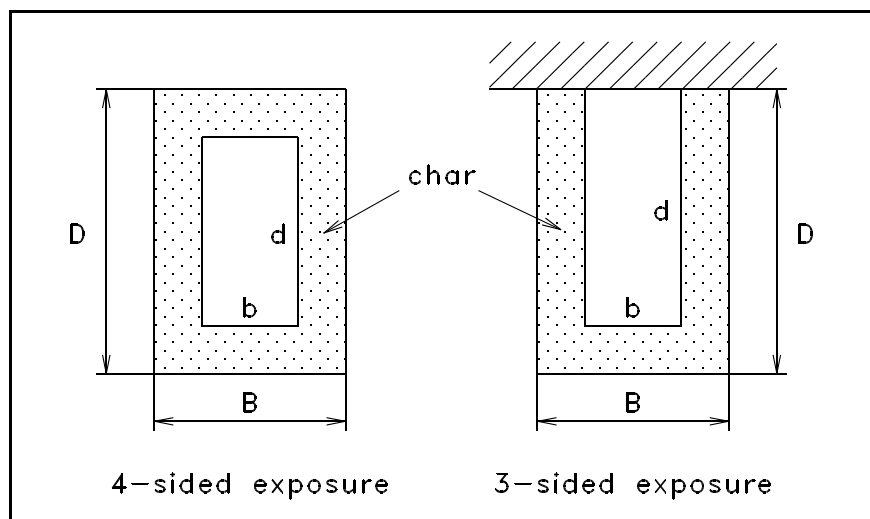

Figure 2 Symbols for cross-sectional dimensions

and d are a function of exposure time, t , and charring rate, β . Assuming the charring rate is identical in every direction, the exposure time t and the dimensions of the initial and remaining cross section are related via the charring rate, β :

$$t = \begin{cases} \frac{B-b}{2\beta} = \frac{D-d}{2\beta} & 4\text{-sided exposure} \\ \frac{B-b}{2\beta} = \frac{D-d}{\beta} & 3\text{-sided exposure} \end{cases}$$

1.3.1 Beams

Lie's method assumed that a beam fails when the reduction in cross section results in a critical value for the section modulus S being reached. Assuming a safety factor reduction of k , a load factor of Z , and a uniform reduction in strength properties of α , the critical section is determined from:

$$kZ \frac{BD^2}{6} = \alpha \frac{bd^2}{6}$$

Given the initial dimensions B (width) and D (depth), the fire endurance time can be calculated by combining equations (1) and (2), and solving the resulting equation for t . The roots to the resulting equations must be solved iteratively. To avoid these cumbersome iterative procedures, Lie approximated his solutions with a set of simple equations that allow for a straightforward calculation of fire endurance time as a function of member size for a realistic range of member dimensions. Lie approximated the solutions for $\alpha=0.8$ and $k=0.33$ to:

$$t_f = \begin{cases} 2.54 ZB \left(4 - \frac{2B}{D}\right) & 4\text{-sided exposure} \\ 2.54 ZB \left(4 - \frac{B}{D}\right) & 3\text{-sided exposure} \end{cases}$$

with

$$Z = \begin{cases} 1.3 & R < 0.5 \\ 0.7 + \frac{0.3}{R} & R \geq 0.5 \end{cases}$$

where R is the ratio of applied to allowable load, t_f is in minutes, and all dimensions are in inches. These are the fire design equations currently used for beams in North American model building codes.

1.3.2 Columns

As noted in the previous section, column failure mode depends on the slenderness ratio. Short columns fail when the reduction in cross section results in a critical value for the cross-sectional area A being reached. Assuming a safety factor reduction of k , a load factor of Z , and a uniform reduction in strength properties of α , the critical section is determined from:

$$kZBD = \alpha bd$$

Long columns fail when the reduction in cross section results in a critical value for the moment of inertia I being reached. Assuming a safety factor reduction of k , a load factor of Z , and a uniform reduction in strength properties of α , the critical section is determined from:

$$kZ \frac{BD^3}{12} = \alpha \frac{bd^3}{12}$$

where D denotes the narrowest dimension of a column section and buckling is assumed to occur in the weakest direction.

Again, given the initial dimensions B (widest dimension) and D (narrowest dimension), the fire endurance time can be calculated for short columns by combining equations (1) and (5) or for long columns by combining equations (1) and (6). Again, to avoid the cumbersome iterative solution of these equations, Lie approximated his solutions with a set of simple equations using equation (2) as an average between equation (5) for short columns and equation (6) for long columns. Therefore, Lie approximated the solutions for $\alpha=0.8$ and $k=0.33$ to:

$$t_f = \begin{cases} 2.54ZD\left(3 - \frac{D}{B}\right) & 4\text{-sided exposure} \\ 2.54ZD\left(3 - \frac{D}{2B}\right) & 3\text{-sided exposure} \end{cases}$$

where Z for short columns ($K_e l/D \leq 11$) follows from

$$Z = \begin{cases} 1.5 & R < 0.5 \\ 0.9 + \frac{0.3}{R} & R \geq 0.5 \end{cases}$$

where Z for long columns ($K_e l/D > 11$) follows from

$$Z = \begin{cases} 1.3 & R < 0.5 \\ 0.7 + \frac{0.3}{R} & R \geq 0.5 \end{cases}$$

where R is the ratio of applied to allowable load, t_f is in minutes, and all dimensions are in inches. These are the fire design equations currently used for columns in North American model building codes.

To determine the fire resistance of columns, Lie used the geometric mean of the equations for the extreme cases of short and long columns. Lie assumed that short columns fail due to crushing, and long columns fail due to buckling. In order to correct the underpredicted failure times for short columns, Lie recommended an increase to the load factor for such columns. In 1991, the NDS provisions for columns were changed from three equations for different ranges of slenderness to a single equation [9]. As a result, the fire design methodology for columns is not consistent with the current procedure for cold design.

Lie verified his method against experimental data from full-size column tests conducted in France [6], England [7], and Germany [8] in the 1960's and early 1970's. In his original paper [4], Lie noted that no beam data were available for comparison. Lie assumed that his calculation method would be valid for beams also, since it was based on the same assumptions and concepts as that for columns. Since Lie's initial work, standard fire test data have now been published for at least 7 heavy timber beams [16][17][18][23].

1.4 NEW MECHANICS-BASED DESIGN METHOD

The current code-accepted method for calculating the fire endurance of exposed, large wood members, developed by Lie, is based on actual fire test results and sound engineering. However, since the final equations are based on empirical solutions fit to beam and column test data, the application of the current method is limited. A new mechanics-based design method was deemed necessary to permit the calculation of fire endurance for exposed, large wood members for other loading conditions and fire exposures not considered by Lie.

The new mechanics-based design method calculates the capacity of fire-resistive exposed wood members using the mechanics assumed by Lie. Failure of a member occurs when the load on the member exceeds the member capacity which has been reduced due to fire exposure. However, actual mechanical and physical properties are used and the capacity of the member is directly calculated for a given period of time. Section properties are computed assuming an effective char rate, B_{eff} , at a given time, t . Average member strength properties are approximated from test data or from procedures used to calculate design properties.

1.4.1 Char Rate

To estimate the reduced cross-sectional dimensions, b and d , the location of the char base must be determined as a function of time on the basis of empirical charring rate data. The char layer can be assumed to have zero strength and stiffness. The physical shape of the remaining section and its load carrying capacity should be adjusted to account for rounding at the corners, and for loss of strength and stiffness in the heated zone. In design there are various documented approaches to account for these affects:

- additional reduction of the remaining section [10][11];
- uniform reduction of the maximum strength and stiffness [4][10][12]; or
- more detailed analysis with subdivision of the remaining section into several zones at different temperatures [13][14].

Extensive char rate data is available for one-dimensional wood slabs. Data is also available for two-dimensional timbers, but most of this data is limited to larger cross-sections. Evaluation of linear char rate models using one-dimensional char rate data suggests that charring of wood is slightly nonlinear, and estimates using linear models tend to underestimate char depth for short time periods (<60 minutes) and overestimate char depth for longer time periods (>60 minutes). One method for correcting for nonlinear char is the use of empirical adjustments, such as the addition of an artificial “char time”, t_c :

$$d_{\text{char}} = \beta(t + t_c) \quad (10)$$

However, these types of corrections are awkward to handle in fire endurance models and tend to over-compensate when adjusting for shorter time periods.

To account for char rate nonlinearity, White developed a nonlinear, one-dimensional char rate model based on the results of 40 one-dimensional wood slab charring tests of various species [24]. White’s non-linear model addressed accelerated charring which occurs early in the fire exposure by applying a power factor to the char depth, x_{char} , to adjust for char rate nonlinearity:

$$t = m x_{\text{char}}^{1.23} \quad (11)$$

However, application of White's model is limited since the char slope (min/in^{1.23}), m , is species-specific and only limited data exists for different wood species fit to White's model. In addition, the model is limited to one-dimensional slabs.

To develop a two-dimensional, nonlinear char rate model, White's non-linear char rate model was modified to enable values for the slope factor m to be estimated using nominal char rate values (in/hr), β_n . The nominal char rate values, β_n , are calculated using measured char depth at approximately one hour. Substitution of this value allows the calculation of the slope factor:

$$1 \text{ hour} = m [(1 \text{ hour}) (\beta_n)]^{1.23} \quad (12)$$

$$m = \beta_n^{-1.23} \quad (13)$$

Substituting and solving for the char depth, x_{char} in terms of time, t :

$$x_{\text{char}} = \beta_n t^{0.813} \quad (14)$$

To account for rounding at the corners and reduction of strength and stiffness of the heated zone, the nominal char rate values, β_n , are increased 20%. The effective char rate can be estimated as:

$$\beta_{\text{eff}} = \frac{1.2 \beta_n}{t^{0.187}} \quad (15)$$

The section properties can be calculated using standard equations for area, section modulus and moment of inertia using reduced cross-sectional dimensions. The dimensions are reduced by $\beta_{\text{eff}} t$ for each surface exposed to fire. Cross-sectional properties for a member exposed on all four sides are:

Table 1.4.1 Cross-Sectional Properties for Four-Sided Exposure

Cross-sectional Property	Four-Sided Example
Area of the cross-section, in ²	$A(t) = (B - 2\beta_{\text{eff}} t)(D - 2\beta_{\text{eff}} t)$
Section Modulus in the major-axis direction, in ³	$S(t) = (B - 2\beta_{\text{eff}} t)(D - 2\beta_{\text{eff}} t)^2/6$
Section Modulus in the minor-axis direction, in ³	$S(t) = (B - 2\beta_{\text{eff}} t)^2(D - 2\beta_{\text{eff}} t)/6$
Moment of Inertia in the major-axis direction, in ⁴	$I(t) = (D_{\text{min}} - 2\beta_{\text{eff}} t)(D_{\text{max}} - 2\beta_{\text{eff}} t)^3/12$
Moment of Inertia in the minor-axis direction, in ⁴	$I(t) = (D_{\text{min}} - 2\beta_{\text{eff}} t)^3(D_{\text{max}} - 2\beta_{\text{eff}} t)/12$

Other exposures can be calculated using this method.

Sides of individual timber decking members are shielded from full fire exposure by adjacent members collectively acting as a joint. Partial exposure can occur as members shrink and joints between members open. The degree of exposure is a function of the view angle of the radiant flame and the ability of hot volatile gases to pass through the joints. When the joint is completely open, such as can occur with butt-jointed timber decking, hot gases will carry into the joint and the sides of the decking members will char. This charring can be conservatively approximated assuming the sides of a member along the joint char at the effective char rate. When the joint is open but covered by sheathing, as with butt-jointed timber decking covered with wood structural panels, passage of hot gases is limited, and tests have shown that charring can be approximated assuming a partial exposure char rate along the joint equal to one-third of the effective char rate [22]. For joints which

are not open, as with tongue-and-groove timber decking, tests have shown that charring of the sides of members is negligible and can be ignored [21][22].

1.4.2 Approximation of Member Strength

Generally, average unheated member strength can be approximated from tests or by using design stresses derived from actual member strength data. To approximate average member strength using allowable design stress values, the allowable design stress value can be multiplied by an adjustment factor, K , to adjust from a 5% exclusion value allowable design value to an average ultimate value [15]. The adjustment factor, K , has two components, the inverse of the applicable design value adjustment factor, $1/k$, and the inverse of the variability adjustment factor, c . To develop general design procedures for glulam and solid-sawn lumber, the following design value adjustment factors and estimates of COV were used to conservatively develop an allowable design stress to average ultimate strength adjustment factor, K :

Table 1.4.2 Allowable Design Stress to Average Ultimate Strength Adjustment Factors

	F	$1/k$	c	Assumed COV	K
Bending Strength	F_b	2.1 ¹	1-1.645 COV _b	0.16 ²	2.85
Tensile Strength	F_t	2.1 ¹	1-1.645 COV _t	0.16 ²	2.85
Compression Strength	F_c	1.9 ¹	1-1.645 COV _c	0.16 ²	2.58
Buckling Strength	E_{05}	1.66 ³	1-1.645 COV _E	0.11 ⁴	2.03

¹ taken from Table 10 of ASTM D 245 *Standard Practice for Establishing Structural Grades and Related Allowable Properties for Visually Graded Lumber*.

² taken from Table 4-6 of *1999 Wood Handbook*.

³ taken from Appendices D and H of *1997 National Design Specification for Wood Construction*.

⁴ taken from Sections 3.3.3.8 and 3.7.1.5 of *1997 National Design Specification for Wood Construction*.

1.4.3 Approximation of Member Capacity

As noted, average member capacity of a wood member exposed to fire for a given time, t , can be estimated using cross-sectional properties reduced for fire exposure time and average ultimate strength properties derived from allowable stress values.

(This page intentionally blank)

Part II: Comparison Between Calculation Methods and Experiments

2.1 General

Given the theoretical derivation of the new mechanics-based design method, existing test results from fire tests of exposed, large wood members were compared against the model predictions. International, as well as North

American, test data were reviewed. The results indicate that the mechanics-based method will more accurately estimate the fire endurance time of tested wood members.

2.2 Beams

Lie was not able to compare his calculation method to experimental data for beams, because such data were not available [4]. Nonetheless, he assumed that it would be valid because the method for beams is conceptually identical to that for columns. At least 7 standard beam tests have been reported in the literature since Lie completed his work.

The Timber Research and Development Association (TRADA) in the UK conducted a series of tests on glulam beams in 1968 [16]. Only one of the tests was not terminated prior to structural failure, which occurred after 53 minutes of exposure to standard BS 476 fire conditions (similar to ISO 834). The ratio of induced load to design load was 80% for this test [13]. The reported allowable stresses were $F_b=2100$ psi and $E=2.0E6$ psi. The report also contained information which permitted the average ultimate bending strength to be estimated as $F_{b-ult} = 7530$ psi. Each beam was braced against lateral translation and rotation at the supports and was loaded through 11 evenly spaced bearing blocks; therefore, an effective length, $l_e=1.84 l_u$ ($l_u =$ full span), was assumed. Using the 1997 NDS behavioral equations, the resisting moment was estimated to be 45,335 ft-lbs compared to an induced moment of 9832 ft-lbs.

To confirm the Lie procedure for

beams, the National Forest Products Association (NFoPA) (now the American Forest & Paper Association), sponsored a test on a Douglas fir glulam beam in 1986 [17]. The beam collapsed after 86 minutes of standard ASTM E 119 fire exposure. The ratio of induced load to design load was 72% for this test [13]. The reported allowable stresses were $F_b=2400$ psi and $E=1.6E6$ psi. Using the 2.85 allowable design stress to average ultimate strength adjustment factor derived in Chapter 1, the average ultimate bending strength was estimated as $F_{b-ult} = 6840$ psi. The beam was braced against lateral translation and rotation at the supports and was loaded through 3 evenly spaced hydraulic cylinders. The center cylinder was braced to maintain a vertical orientation; however, the beam was not braced. Therefore, an effective length, $l_e=1.84 l_u$ ($l_u =$ full span), was assumed. Using the 1997 NDS behavioral equations, the resisting moment was estimated to be 222,356 ft-lbs compared to an induced moment of 55,855 ft-lbs.

More recently, Dayeh and Syme reported results for Brush box and Radiata pine glulam beams tested by the Forestry Commission of New South Wales (FCNSW) according to AS 1720 Part 1 [18][26]. The ratios of induced load to design load were 46% and 18% and failure times were 59 minutes and 67 minutes for the Brush box and

Radiata pine beam, respectively. Dayeh and Syme estimated the average ultimate strength for the Brush box beam as $F_b=7250$ psi and $E=2.2E6$ psi. The beam was braced against lateral translation and rotation at the supports and was loaded at 2 evenly spaced load points. The beam was apparently braced at the load points; therefore, an effective length, $l_e=1.68 l_u$ ($l_u = \text{full span}/3$), was assumed. Using the 1997 NDS behavioral equations, the resisting moment was estimated to be 161,569 ft-lbs compared to an induced moment of 74,789 ft-lbs.

Dayeh and Syme estimated the average ultimate strength for the Radiata pine beam as $F_b=5200$ psi and $E=1.8E6$ psi. The beam was braced against lateral translation and rotation at the supports and was loaded at 2 evenly spaced load points. The beam was apparently braced at the load points; therefore, an effective length, $l_e=1.68 l_u$ ($l_u = \text{full span}/3$), was assumed. Using the 1997 NDS behavioral equations, the resisting moment was estimated to be 116,064 ft-lbs compared to an induced moment of 20,504 ft-lbs.

In 1997, the American Forest & Paper Association (AF&PA) conducted a series of four experimental beam tests at Southwest Research Institute (SwRI) [23]. The primary objectives of the tests were to evaluate the effect of load on the fire resistance of glulam beams, and to determine whether the load factor equation in Lie's calculation method is valid for load ratios lower than 50%. The same type of beam was used as for the test

conducted by NFoPA, so that the results from that test would provide an additional data point for the load ratio curve. The first of the four tests was conducted without external load, but with an extensive number of thermocouples distributed across the section to determine char rates in different directions as a function of time. In the remaining three tests, the beams were loaded at 27%, 44%, and 91% of the design load. The reported allowable stresses were $F_b=2400$ psi and $E=1.6E6$ psi. Using the 2.85 allowable design stress to average ultimate strength adjustment factor derived in Chapter 1, the average ultimate bending strength was estimated as $F_{b,ult} = 6840$ psi. Each beam was braced against lateral translation and rotation at the supports and was loaded at 2 evenly spaced load points. The beam was braced at the load points; therefore, an effective length, $l_e=1.68 l_u$ ($l_u = \text{full span}/3$), was assumed. Using the 1997 NDS behavioral equations, the resisting moment was estimated to be 222,762 ft-lbs compared to induced moments of 18,937 ft-lbs, 30,707 ft-lbs and 65,075 ft-lbs for the 27%, 44%, and 91% design load cases, respectively. The corresponding failure times were 147 min, 114 min, and 85 minutes, respectively.

The section dimensions, average densities, resisting moment and induced moment for the 7 beam tests are summarized in Table 2.2a. The measured times to structural failure are compared to calculated results in Table 2.2b and in Figure 3.

Table 2.2a Beams tested

Designation	Breadth (in)	Depth (in)	Specific Gravity	F_{b-ult} (psi)	E $\times 10^6$ (psi)	Resisting Moment (ft-lbs)	Induced Moment (ft-lbs)
TRADA	5.5	9	0.49	7530	2.0	45,528	9,832
NFoPA	8.75	16.5	0.47	6840	1.6	222,356	55,855
AF&PA-27	8.75	16.5	0.47	6840	1.6	222,762	18,937
AF&PA-44	8.75	16.5	0.47	6840	1.6	222,762	30,707
AF&PA-91	8.75	16.5	0.47	6840	1.6	222,762	65,075
FCNSW-BB	5.9	16.5	0.82	7250	2.2	161,569	74,789
FCNSW-RP	5.9	16.5	0.52	5200	1.8	116,064	20,504

Table 2.2b Measured and Calculated Beam Fire Resistance Times

Designation	Measured t_r (min)	Calculated t_r (min)	
		Lie Method ^{1,2}	Mechanics-Based Method ³
TRADA	53	51	52
NFoPA	86	86	84
AF&PA-27	147	100	134
AF&PA-44	114	100	125
AF&PA-91	85	79	92
FCNSW-BB	59	71	41
FCNSW-RP	67	71	72

¹ Assumed a char rate of 1.42 in/hr.² Used stated design load ratio from report.³ Assumed a char rate of 1.5 in/hr.

Figure 3 Comparison of Predicted to Observed Time to Failure (Wood beams exposed on three sides)

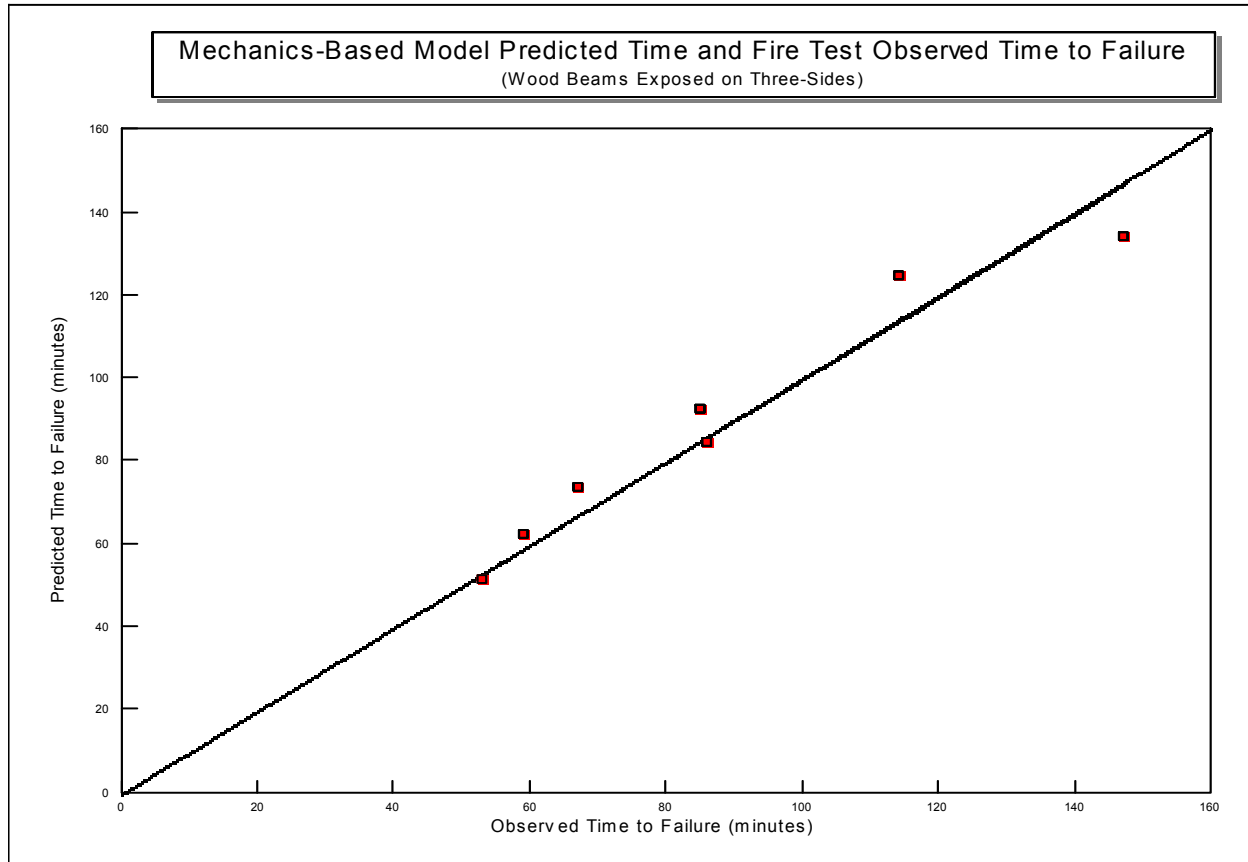

2.3 Columns

Lie verified his method against experimental data for columns obtained in France [6], England [7], and Germany [8] in the 1960's and early 1970's. In this report, the same data sets are used to evaluate the new mechanics-based calculation method.

Fackler reported results for 5 columns that were tested in the early 1960's at the laboratories of CSTB in France [6]. Two columns were glued-laminated, and the remaining three were bolted or nailed together. The two glulam columns were identical except for the type of adhesive. For one column, the laminates were glued together with a melamine adhesive. For the other column, a urea-formaldehyde adhesive was used. It was concluded that the type of adhesive did not have an effect on fire

performance, because time to failure was identical for the two tests. Lie performed his calculations assuming the columns were tested under full design load, as mentioned in Fackler's report. Based on estimates of average ultimate bending strength for French Maritime Pine reported in the literature [19], the average ultimate compression strength was estimated as $F_{c-ult} = 2565$ psi ($0.4 F_{c-ult}$). The literature also reported $E=1.6E6$ psi. Using the 1997 NDS behavioral equations and an effective length $l_e=90$ in, the resisting capacity was estimated to be 132,365 lbs compared to an induced load of 39,790 lbs. The section dimensions, , specific gravities, mechanical properties, resisting capacities and induced loads for the 2 French column tests are summarized in Table 2.3a.

Table 2.3a Columns tested in France

Designation	Depth (in)	Breadth (in)	Specific Gravity (lb/ft ³)	F_{c-ult} (psi)	E x10 ⁶ (psi)	Resisting Capacity (lbs)	Induced Load (lbs)
CSTB44	7	7.875	0.56	2565	1.6	132,365	39,790
CSTB45	7	7.875	0.56	2565	1.6	132,365	39,790

Stanke et al. reported results for a very large number of glulam columns that were tested in Germany in the 1970's [7].

Two types of adhesives were used; recorsinol (R designation), and urea based (H designation). As in the French tests, it was found that type of adhesive did not have a systematic effect on fire resistance. The load ratios were reported by Stanke et al. as 1.00, 0.75, and 0.50. Average ultimate compression strengths and E values were reported for some column tests. While the actual species tested were not identified, the specific gravity for the laminations were recorded. Using the reported specific gravity and mechanical properties, average ultimate compression strengths and E values were estimated for the other columns tested. Using the 1997 NDS behavioral equations and an effective length $l_e=144$ in, the resisting capacities for each of the columns were estimated. The section dimensions, specific gravities, mechanical properties, resisting capacities and induced loads for each of the German column tests are summarized in Table 2.3b.

Malhotra and Rogowski reported results for 16 glulam column tests that were conducted at the Fire Research Station in the UK [8]. The tests were statistically designed to determine the effect of 4 factors at 3 to 4 levels. The factors and levels were:

- species (first letter in designation): Douglas fir (F), Western hemlock (H), European redwood (R), and Western

- red cedar (C);
- adhesive (second letter in designation): urea (U), casein (C), recorsinol (R), and phenolic (P);
- shape: 9 in. x 9 in., 12 in. x 6.9 in., and 15 in. x 5.6 in.; and
- test load: 100% of design, 50% of design, and 25% of design.

Statistical analysis indicated that some columns with casein adhesive performed systematically below average. Since these adhesives are not commonly used today for glulam, the test data were discarded for the purpose of this report. The load ratios were reported by Malhotra and Rogowski as 1.00, 0.50, and 0.25. Allowable compression stresses and E values were reported by Malhotra and Rogowski. Using the allowable/ultimate adjustments reported in the TRADA beam tests [16], average ultimate compression strengths and E values were estimated. Using the 1997 NDS behavioral equations and an effective length $l_e=82$ in (reported by Malhotra and Rogowski), the resisting capacities for each of the columns were estimated. The section dimensions, specific gravities, mechanical properties, resisting capacities and induced loads for each of the British column tests are summarized in Table 2.3c. The measured times to structural failure for the three separate series of column tests are compared to calculated results in Table 2.3d and Figure 4.

Table 2.3b Columns tested in Germany by Stanke et al.

Designation	Depth (in)	Breadth (in)	Specific Gravity	F_{c-ult} (psi)	E $\times 10^6$ (psi)	Resisting Capacity (lbs)	Induced Load (lbs)
R14A	5.5	5.5	0.44	7368	2.5	84,644	19,026
R14B	5.5	5.5	0.45	7929 ^a	2.3 ^b	80,310	19,026
R14C	5.5	5.5	0.45	8131 ^a	2.4 ^b	82,217	9,524
R14D	5.5	5.5	0.43	7447 ^a	2.2 ^b	75,740	14,264
H14A	5.5	5.5	0.44	8050	2.0	70,825	19,026
H14B	5.5	5.5	0.48	7652	2.4	82,598	19,026
H14C	5.5	5.5	0.45	8131 ^a	2.4 ^b	82,217	9,524
H14D	5.5	5.5	0.43	7447 ^a	2.2 ^b	75,740	14,264
H14/24A	5.5	9.5	0.41	6243 ^a	1.7 ^b	99,126	32,628
H14/24B	5.5	9.5	0.41	6169 ^a	1.6 ^b	98,033	32,628
H14/30A	5.5	11.75	0.45	6914 ^a	1.7 ^b	130,414	40,786
H14/30B	5.5	11.75	0.47	8690	2.7	198,238	20,393
H14/30C	5.5	11.75	0.46	7165 ^a	1.8 ^b	134,828	20,393
H14/40	5.5	15.75	0.45	6675 ^a	1.6 ^b	158,898	54,234
R15A	5.875	5.875	0.38	5995 ^a	1.8 ^b	78,944	24,030
R15B	5.875	5.875	0.38	5970 ^a	1.8 ^b	78,629	24,030
H15A	5.875	5.875	0.40	6515 ^a	1.9 ^b	85,341	24,030
H15B	5.875	5.875	0.37	5868 ^a	1.7 ^b	77,371	24,030
R16	5.875	5.875	0.31	4302 ^a	1.3 ^b	72,417	29,432
H16A	6.25	6.25	0.37	5723 ^a	1.7 ^b	94,688	29,432
H16B	6.25	6.25	0.40	6595 ^a	1.9 ^b	108,172	29,432
R16/30	6.25	11.75	0.41	5944 ^a	1.5 ^b	163,784	27,558
H16/30A	6.25	11.75	0.42	6229 ^a	1.6 ^b	171,131	55,116
H16/30B	6.25	11.75	0.44	6666 ^a	1.7 ^b	182,354	55,116
H16/30C	6.25	11.75	0.43	6470 ^a	1.6 ^b	177,337	55,116
H16/30D	6.25	11.75	0.40	5710 ^a	1.5 ^b	157,743	27,558

Table 2.3b (cont'd) Columns tested in Germany by Stanke et al.

Designation	Depth (in)	Breadth (in)	Specific Gravity	F_{c-ult} (psi)	E $\times 10^6$ (psi)	Resisting Capacity (lbs)	Induced Load (lbs)
R20A	7.875	7.875	0.40	5931	1.6	199,681	56,438
R20B	7.875	7.875	0.39	6657	1.7	219,632	56,438
R20C	7.875	7.875	0.46	9003	2.2	288,658	28,219
R20D	7.875	7.875	0.43	5685 ^a	1.6 ^b	198,702	28,219
H20A	7.875	7.875	0.38	5903	1.7	209,239	56,438
H20B	7.875	7.875	0.39	6031	1.8	218,955	56,438
H20C	7.875	7.875	0.45	8676	2.1	270,840	28,219
H20D	7.875	7.875	0.45	7370 ^a	2.0 ^b	254,219	28,219
H20/40A	7.875	15.75	0.44	6651 ^a	1.6 ^b	413,483	112,877
H20/40B	7.875	15.75	0.45	5415 ^a	1.3 ^b	340,466	112,877
H24A	9.5	9.5	0.40	5639 ^a	1.5 ^b	344,680	89,949
H24B	9.5	9.5	0.38	6616 ^a	1.8 ^b	401,964	89,949
H26A	10.25	10.25	0.42	6346 ^a	1.7 ^b	485,005	110,672
H26B	10.25	10.25	0.42	5579 ^a	1.5 ^b	428,165	110,672
R27A	10.625	10.625	0.38	5220	1.3	428,663	121,034
R27B	10.625	10.625	0.40	5504	1.6	483,442	121,034
R27C	10.625	10.625	0.41	6229 ^a	1.6 ^b	528,292	121,034
H27A	10.625	10.625	0.42	6216	1.9	555,826	121,034
H27B	10.625	10.625	0.40	5448	1.4	463,536	121,034
H27C	10.625	10.625	0.41	6181 ^a	1.6 ^b	524,303	121,034
H28A	11	11	0.40	5806 ^a	1.5 ^b	543,889	132,939
H28B	11	11	0.42	6260 ^a	1.6 ^b	585,187	132,939
H40	15.75	15.75	0.41	5659 ^a	1.4 ^b	1,257,232	308,647

^a Compression strength estimated from the regression: $F_{c-ult} = 39,922 d^{-0.185} G^{1.609}$ ($r^2 = 0.76$)

^b Modulus of elasticity estimated from the regression: $E = 15.1 \times 10^6 d^{-0.390} G^{1.490}$ ($r^2 = 0.84$)

Table 2.3c Columns tested in England by Malhotra et al.

Designation	Depth (in)	Breadth (in)	Specific Gravity	F_{c-ult} (psi)	E $\times 10^6$ (psi)	Resisting Capacity (lbs)	Induced Load (lbs)
FU1	9	9	0.59	5197	1.7	396,190	71,980
FR3	5.6	15	0.59	5197	1.7	327,262	35,990
FP4	9	9	0.59	5197	1.7	396,190	143,962
HU5	9	9	0.54	4454	1.5	339,409	31,030
HR7	6.9	12	0.54	4454	1.5	318,144	62,060
HP8	9	9	0.54	4454	1.5	339,409	62,060
RU9	5.6	15	0.54	3961	1.2	241,977	55,226
RR11	9	9	0.54	3961	1.2	299,826	110,452
RP12	6.9	12	0.54	3961	1.2	278,740	27,613
CU13	6.9	12	0.38	3218	1.0	227,700	89,508
CR15	9	9	0.38	3218	1.0	244,188	44,754
CP16	5.6	15	0.38	3218	1.0	198,645	44,754

Table 2.3d Measured and Calculated Column Fire Resistance Times

Designation	Measured t_f (min)	Calculated t_f (min)	
		Lie Method ^{1,2}	Mechanics-Based Method ³
CSTB44	48	38	45
CSTB45	48	38	45
R14A	29	28	25
R14B	21	28	24
R14C	36	36	36
R14D	29	31	28
H14A	26	28	22
H14B	27	28	25
H14C	43	36	36
H14D	34	31	28
H14/24A	35	34	21
H14/24B	32	34	21
H14/30A	39	35	23
H14/30B	59	46	43
H14/30C	53	46	36
H14/40	43	37	22
R15A	26	30	22
R15B	27	30	22
H15A	31	30	23
H15B	30	30	22
R16	30	32	18
H16A	31	32	23
H16B	37	32	26
R16/30	58	51	41
H16/30A	40	39	26
H16/30B	52	39	28
H16/30C	45	39	27
H16/30D	57	51	40
R20A	34	40	35
R20B	48	40	37
R20C	64	52	61
R20D	61	52	53

Table 2.3d (cont'd) Measured and Calculated Column Fire Resistance Times

Designation	Measured t_r (min)	Calculated t_r (min)	
		Lie Method ^{1,2}	Mechanics-Based Method ³
H20A	42	40	37
H20B	43	40	38
H20C	60	52	59
H20D	52	52	58
H20/40A	65	50	41
H20/40B	74	50	35
H24A	60	48	50
H24B	56	48	55
H26A	62	52	62
H26B	62	52	57
R27A	57	54	56
R27B	54	54	64
R27C	76	54	65
H27A	59	54	70
H27B	56	54	60
H27C	71	54	65
H28A	59	56	67
H28B	67	56	70
H40	114	96	123
FU1	55	60	77
FR3	74	48	49
FP4	45	55	51
HU5	73	60	96
HR7	49	55	54
HP8	69	69	77
RU9	47	55	35
RR11	45	55	50
RP12	76	69	68
CU13	35	51	35
CR15	43	69	76
CP16	39	48	36

¹ Assumed a char rate of 1.42 in/hr.² Used stated design load ratio from report.³ Assumed a char rate of 1.5 in/hr.

Figure 4 Comparison of Predicted to Observed Time to Failure (Wood columns exposed on four sides)

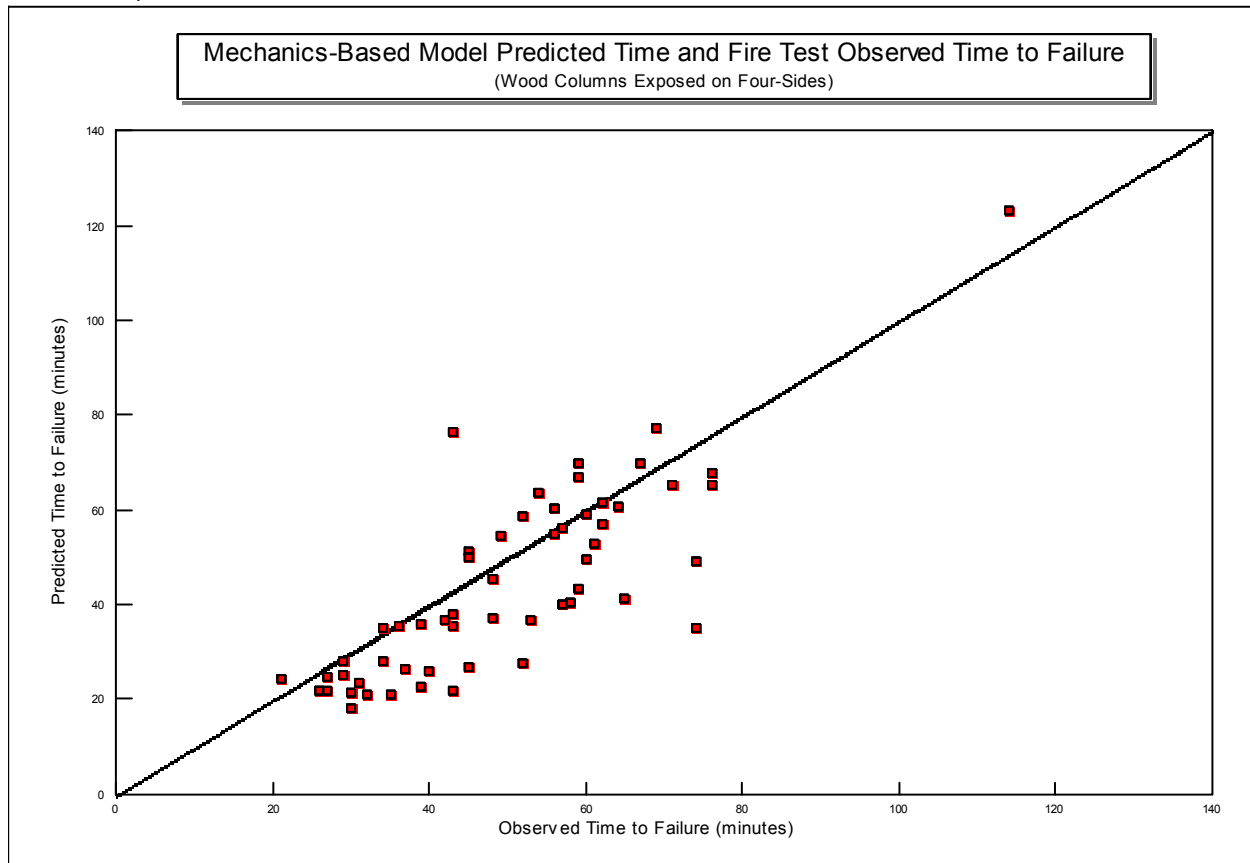

2.4 Tension Members

In 2000, the American Forest & Paper Association sponsored a series of four tension member tests at the U.S. Forest Products Laboratory (FPL) [27]. The primary objective of these tests was to validate this new mechanics-based model against full-size tests of large, exposed wood members. The Douglas fir members were 117 inches long and loaded with a tension apparatus specially designed to induce intended tension loads. The center 72 inches of each member spanned through an intermediate-scale furnace and was subjected to an E119 exposure.

Using the 1997 NDS behavioral equations, the resisting capacities were estimated for each of the tension members. Due to a limitation in the furnace opening width, members were limited to less than 9

inches in width. In order to accommodate this limitation and to test members for up to two hours, load ratios in the range of 0.15-0.48 were used.

In the first two tests, it was determined that there was an unintended eccentricity caused by the bolted connection of the member to the test apparatus that resulted in a moment being induced in the member. This eccentricity induced a particularly large moment in the second test. A fourth test was conducted to repeat the configuration of the second test with the unintended eccentricity removed. Correcting the unintended eccentricity resulted in good agreement between the observed and predicted failure times.

The section dimensions, mechanical properties, resisting capacities and induced loads for the first, third and fourth tension members are provided in Table 2.4a. The

measured times to structural failure are compared to calculated results in Table 2.4b and in Figure 5.

Table 2.4a Tension members tested

Designation	Breadth (in)	Depth (in)	F_{t-ult} (psi)	Resisting Capacity (lbs)	Induced Load (lbs)
Test 1 - Lumber 4x6	3.375	5.313	2130	38,223	3,005
Test 3 - Glulam 5-1/8 x 9	5.063	8.813	4560	203,437	34,392
Test 4 - Glulam 8-3/4 x 9	8.75	8.563	4560	341,644	19,580 ¹

¹ For this test, a constant load of 6,000 lbs was applied for the first 120 minutes of the test. After 120 minutes, the load was gradually increased until failure occurred.

Table 2.4b Measured and Calculated Tension Member Fire Resistance Times

Designation	Measured t_f (min)	Calculated t_f (min)
Test 1 - Lumber 4x6	42	44
Test 3 - Glulam 5-1/8 x 9	58	60
Test 4 - Glulam 8-3/4 x 9	124	126

¹ Assumed a char rate of 1.5 in/hr.

Figure 5 Comparison of Predicted to Observed Time to Failure (Wood tension members exposed on four sides)

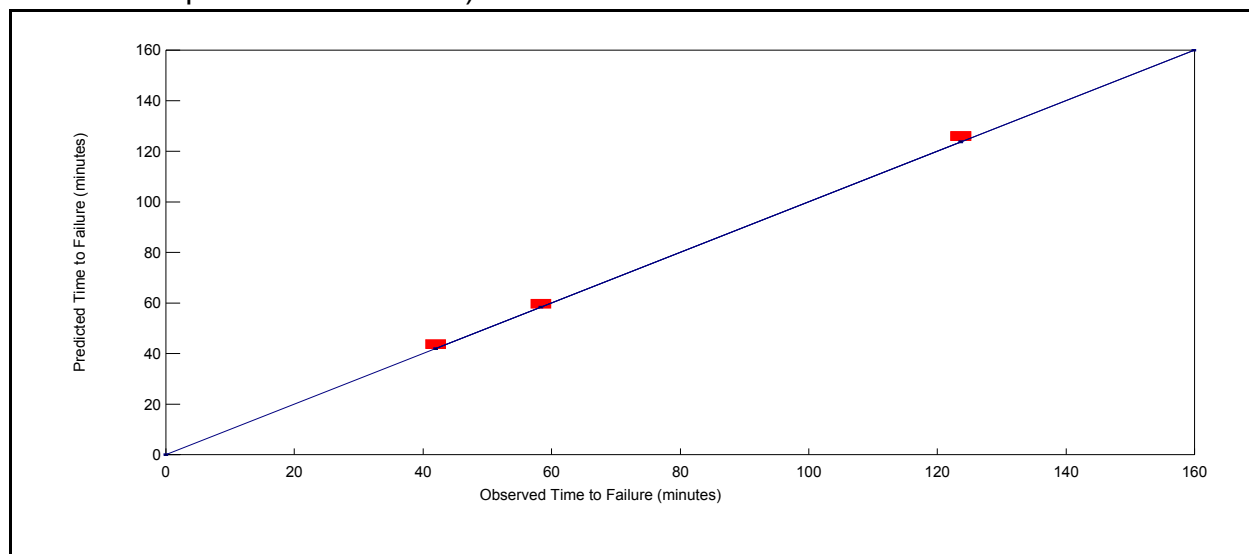

2.5 DECKING

In 1964, Underwriters' Laboratories (UL) conducted a series of four tests on roof constructions for the Douglas Fir Plywood Association (now APA - The Engineered Wood Association) [21]. Two of the tests, referred to as UL#2 and UL#4, were conducted on exposed timber decks consisting of 5.5 in x 1.5 in single tongue-and-groove Douglas fir planks. The decks were loaded to 46% and 59% of the design load for tests UL#2 and UL#4 respectively. The reported thermal penetration time was identical for the two tests at 20 min. First structural failure of a plank is not specifically mentioned in the report. However, for test UL#2 it is mentioned that deflection was noticeable (1.25 in. at the center of the deck) 13 minutes after the start of the test, and that the unsupported ends of some planks started to warp at 24 minutes. For test UL#4, noticeable deflection was observed at 11 minutes and warping was observed at 18 minutes.

In 1969, the American Iron and Steel Institute conducted a comprehensive experimental program at Ohio State University (OSU) [22]. The program included six tests on exposed timber floor decks. The first two decks, referred to as HT1 and HT2, consisted of 1.625 in. x 3.625 in. members on edge and covered with $\frac{3}{4}$ in. wood flooring. Flame-through for the two tests was reported at 61 and 69 minutes respectively. The first two decks were loaded at 21% of design load, and structural failure of the bottom decking (not total structural failure) was reported at 62 minutes and 56 minutes for HT1 and HT2, respectively. Heavy charring occurred on

the bottom of the decking, while lighter charring occurred on the sides. To use the mechanics-based model, charring on the sides due to the partial exposure at the butt-joints was addressed by assuming a charring rate of 30% of the effective charring rate for wood which is fully exposed.

The remaining four decks, referred to as HT3 through HT6, consisted of 5.625 in. x 2.625 in. tongue-and-groove planks, covered with $\frac{3}{4}$ " wood flooring. Flame-through for the four tests was reported at 54, 31, 35, and 49 minutes respectively. The HT3 and HT4 decks were loaded at 42% of design load, and structural failure was reported at 54 minutes for HT3 (and not reported for HT4). The HT5 and HT6 decks were loaded at 50% of design load, and structural failure was reported at 45 minutes for HT6 (and not reported for HT5). Note that the fuel supply to the burners instead of the temperature-time curve in the furnace was controlled during the even-numbered tests. This resulted in slightly more severe exposure conditions than in the odd-numbered tests, which were conducted strictly according to ASTM E 119.

Using the 2.85 allowable design stress to average ultimate strength adjustment factor derived in Chapter 1, the ratio of induced moment to average ultimate bending moment can be estimated for each deck configuration was estimated as $F_{b-ult} = 6840$ psi. The section dimensions, induced moment to resisting moment ratio, measured structural failure time and calculated failure time are summarized in Table 2.4 and Figure 5.

Table 2.5 Measured and Calculated Decking Structural Fire Resistance Times

Designation	Species	Breadth (in)	Depth (in)	$\frac{M_{\text{induced}}}{M_{\text{ult}}}$	Measured (Structural) t_f (min)	Calculated (Structural) t_f^1 (min)
UL#2	Douglas fir	5.5	1.5	0.16	24+	25
UL#4	Douglas fir	5.5	1.5	0.21	18+	23
HT1	Subalpine fir	1.625	3.625	0.07	62	58
HT2	Subalpine fir	1.625	3.625	0.07	56	58
HT3	Southern pine	5.625	2.625	0.15	54	49
HT4	Southern pine	5.625	2.625	0.15	NR	49
HT5	Southern pine	5.625	2.625	0.18	NR	45
HT6	Southern pine	5.625	2.625	0.18	45	45

NR=Not Reported

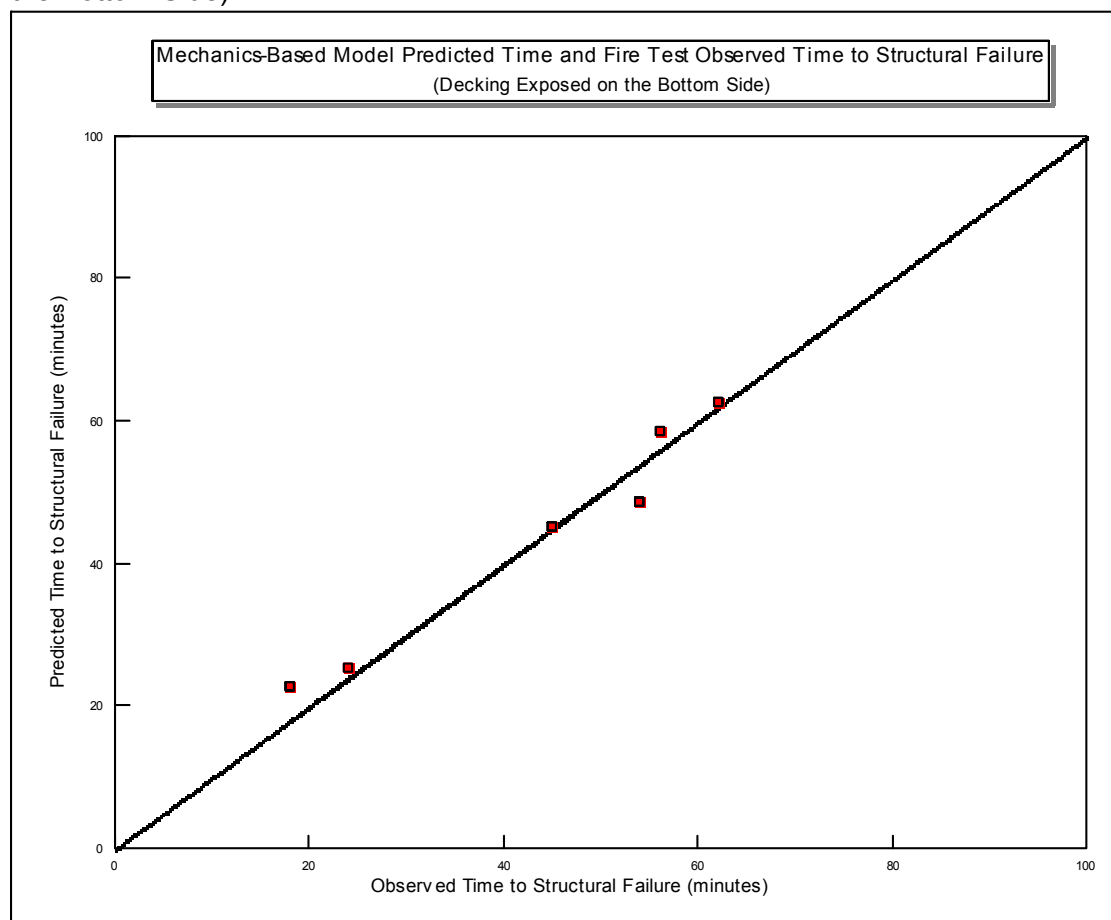
¹ Assumed a char rate of 1.5 in/hr.**Figure 6** Comparison of Predicted to Observed Time to Failure (Decking Exposed on the Bottom Side)

2.6 SUMMARY

As can be seen in Figures 3, 4, 5 and 6, the new mechanics-based method which uses a standard nominal char rate, $B_n=1.5$ in/hr, for all species, a non-linear char rate adjustment, a constant char acceleration factor of 1.2, and a standard variability adjustment in the design to ultimate adjustment factor predicts average endurance times for beams, columns and

decks that closely track actual endurance times for tested members. While further refinements of this method are possible, these comparisons suggest that standardized adjustments to design stresses, a standardized accelerated char rate, and the use of the *NDS* behavioral equations adequately address fire design of large, exposed wood members.

Part III: Design Procedures for Exposed Wood Members

3.1 Design Procedures for Wood Members

Failure of a member occurs when the load on the member exceeds the member capacity which has been reduced due to fire exposure. This new mechanics-based design procedure calculates the capacity of exposed wood members using basic wood engineering mechanics and has been incorporated into the 2001 *National Design Specification® for Wood Construction (NDS®)* [9] for fire resistance calculations of up to 2 hours. Actual mechanical and physical properties of the wood are used and the capacity of the member is directly calculated for a given period of time. Section properties are computed assuming an effective char rate, β_{eff} , at a given time, t . Reductions of strength and stiffness of wood directly adjacent to the char layer are addressed by accelerating the char rate 20%. Average member strength properties are approximated from existing accepted procedures used to calculate design properties. Finally, wood members are designed using accepted engineering procedures found in the *NDS*.

3.1.1 Char Rate

The effective char rate to be used in this procedure can be estimated from published nominal one-hour char rate data using the following equation:

$$\beta_{eff} = \frac{1.2 \beta_n}{t^{0.187}}$$

Where;

- β_{eff} = Effective char rate (in/hr), adjusted for exposure time, t
- β_n = Nominal char rate (in/hr), linear char rate based on 1-hour exposure
- t = Exposure time (hrs)

A nominal char rate, β_n , of 1.5 inches/hour is commonly assumed for solid-sawn and glued-laminated softwood members. For $\beta_n = 1.5$ inches/hour, the effective char rates, β_{eff} , and effective char layer thicknesses, a_{char} , for each exposed surface are:

**Table 3.1.1 EFFECTIVE CHAR RATES and CHAR LAYER THICKNESSES
(for $\beta_n = 1.5$ inches/hour)**

Required Fire Endurance (hr)	Effective Char Rate, β_{eff} (in/hr)	Effective Char Layer Thickness, a_{char} (in)
1-Hour	1.8	1.8
1½-Hour	1.67	2.5
2-Hour	1.58	3.2

The section properties can be calculated using standard equations for area, section modulus and moment of inertia using the reduced cross-sectional dimensions. The dimensions are reduced by the effective char layer thickness, a_{char} , for each surface exposed to fire.

3.1.2 Approximation of Member Strength and Capacity

For fire design, the estimated member capacity is evaluated against the loss of cross-section and mechanical properties as a result of fire exposure. While the loss of cross-section and mechanical

properties are addressed by reducing the section properties using the effective char layer thickness, the average member strength properties must be determined from published allowable design stresses. The average member capacity of a wood member exposed to fire for a given time, t , can be estimated using the average member strength and reduced cross-sectional properties. For solid-sawn, glued-laminated timber, and structural composite lumber wood members, the average member capacity can be approximated by multiplying the allowable design values by the following adjustment factors, K :

Table 3.1.2 Allowable Design Stress to Average Ultimate Strength Adjustment Factor

Member Capacity	K
Bending Moment Capacity, in-lbs.	2.85
Tensile Capacity, lbs.	2.85
Compression Capacity, lbs.	2.58
Beam Buckling Capacity, lbs.	2.03
Column Buckling Capacity, lbs.	2.03

Axial/bending interactions can be calculated using this procedure. All member strength and cross-sectional properties should be adjusted prior to the interaction calculations. The interaction calculations should then be conducted in accordance with appropriate *NDS* provisions.

3.1.3 Design of Members

Once the member capacity has been determined using the effective section properties from Section 3.1.1 and the member strength approximations from Section 3.1.2, the wood member can be designed using accepted *NDS* design procedures for the following loading condition:

$$D + L \leq K R_{ASD}$$

Where;

- D = Design dead load
- L = Design live load
- R_{ASD} = Nominal allowable design capacity
- K = Factor to adjust from nominal design capacity to average ultimate capacity

3.2 Design Procedures for Timber Decks

Timber decks consist of planks that are at least 2 in. thick. The planks span the distance between supporting beams, and can be arranged in different ways depending on the available lengths [20]. Usually, a single or double tongue-and-groove joint is used to connect adjoining planks, but splines or butted joints are also common.

In order to meet requirements for a given fire resistance rating, a timber deck needs to maintain its thermal separation function and load carrying capacity for the specified duration of exposure to standard fire conditions. The thermal separation requirement limits the temperature rise on the unexposed side of the deck to 250 °F above ambient temperature over the entire surface area, or 325 °F above ambient temperature at a single location. When the limits can not be met by the decking

alone, additional floor coverings can be used to increase the thermal separation time. The calculation procedures in this report do not address the adequacy of thermal separation.

The load carrying capacity requires that the deck carry the specified load for the required endurance time. The structural design procedures described in Section 3.1 also apply to timber decks. Single and double tongue-and-groove (T&G) decking should be designed as an assembly of wood beams fully-exposed on one face. Butt-jointed decking should be designed as an assembly of wood beams partially-exposed on the sides and fully-exposed on one face. To compute the effects of partial exposure of the decking on its sides, the char rate for this limited exposure should be reduced to 33% of the effective char rate.

3.3 Special Provisions for Glued Laminated Timber Beams

For glued laminated timber bending members rated for 1-hour fire endurance, an outer tension lamination shall be substituted for a core lamination on the tension side for unbalanced beams and on both sides for balanced beams. For glued laminated timber bending members rated for 1½ or 2-hour fire endurance, two outer tension laminations shall be substituted for two core laminations on the tension side for unbalanced beams and on both sides for balanced beams.

3.4 Wood Connections

Where one-hour fire endurance is required, connectors and fasteners must be protected from fire exposure by wood, fire-rated gypsum board, or any coating approved for the required endurance time. Typical details for commonly used fasteners and connectors in timber framing are shown in Figure 7 (Beam to Column Connection Not Exposed to Fire), Figure 8 (Beam to Column Connection Exposed to Fire Where Appearance is a Factor), Figure 9 (Ceiling Construction), Figure 10 (Beam to Column Connection Exposed to Fire Where Appearance is Not a Factor), Figure 11 (Column Connections - Covered), Figure 12 (Beam to Girder - Concealed Connection).

3.5 Application Guidelines for Wood Members

For given member sizes, different endurance times can be achieved by varying the percent of maximum design load applied to the member. Examples of the relationship between section size, load ratio, and fire endurance time are provided in the following sections. Tabulated design aids have been developed for some common design cases and are provided in the Appendix.

Figure 7.
Beam to Column Connection
Connection Not Exposed to Fire

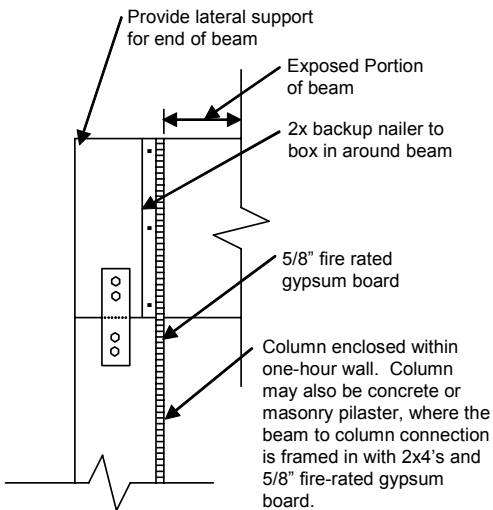

ELEVATION

Figure 8.
Beam to Column Connection
Connection Exposed to Fire Where
Appearance is a Factor

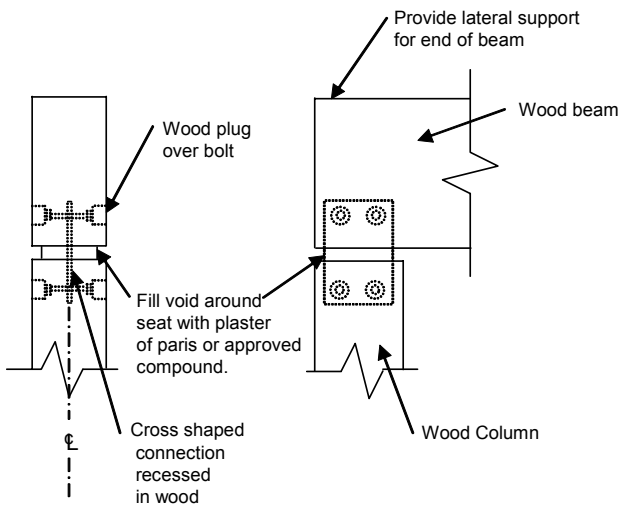

END VIEW

ELEVATION

Figure 9.
Ceiling Construction

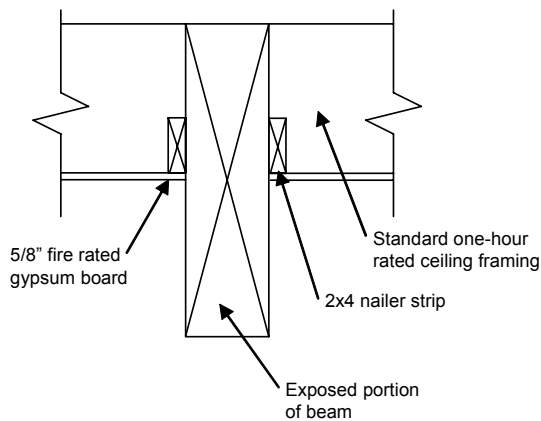

SECTION

Figure 10.
Beam to Column Connection
Connection Exposed to Fire Where
Appearance is a Factor

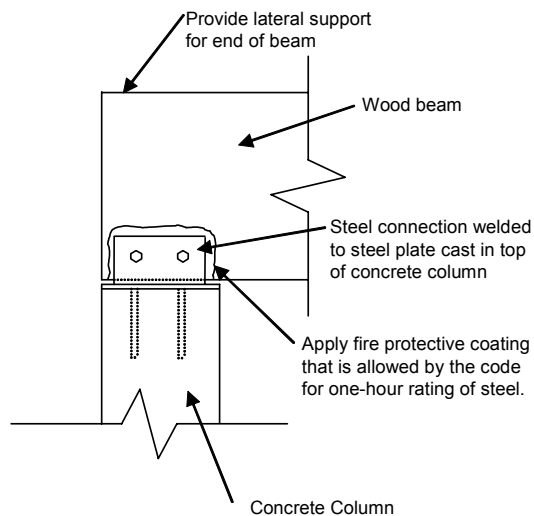

ELEVATION

Figure 11.
Column Connections - Covered

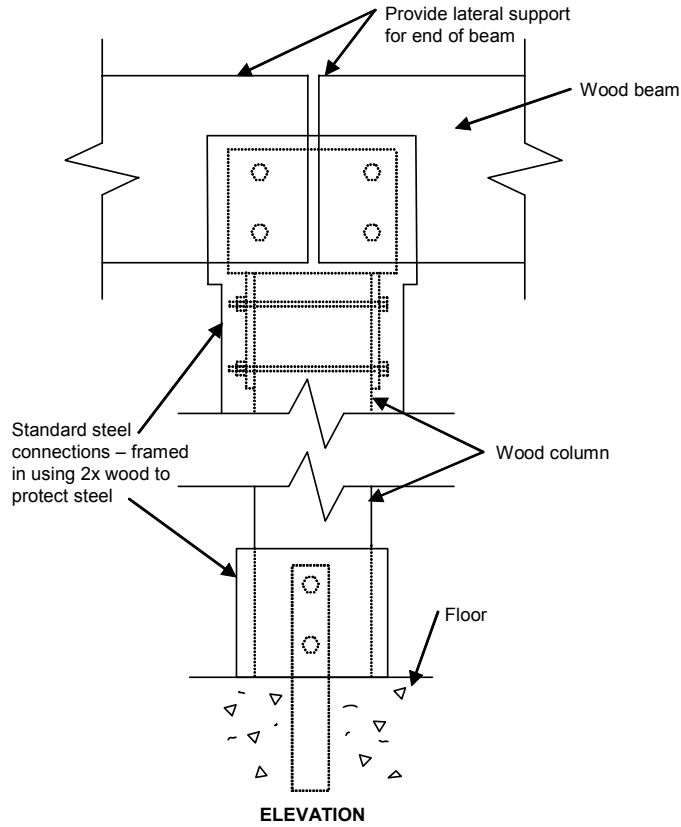
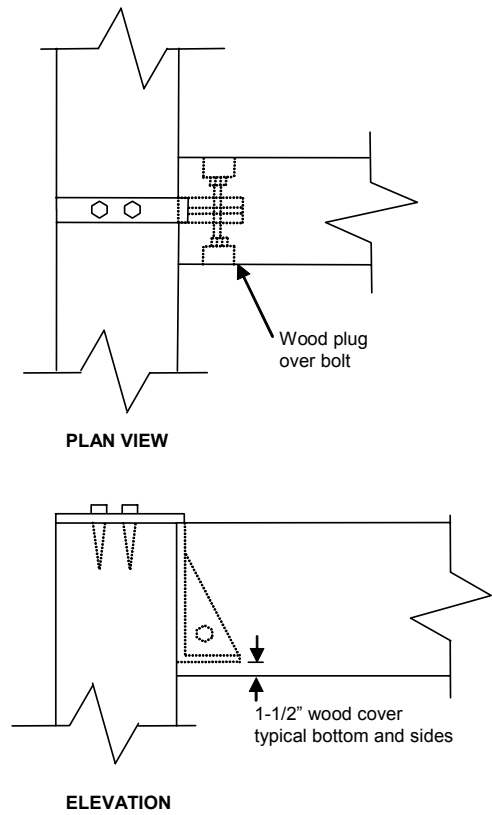

Figure 12.
Beam to Girder - Concealed Connection



Exposed Beam Example - Allowable Stress Design

Douglas fir glulam beams span $L=18'$, and are spaced at $s=6'$. The design loads are $q_{live}=100$ psf and $q_{dead}=25$ psf. Timber decking nailed to the compression edge of the beams provides lateral bracing. Calculate the required section dimensions for a one-hour fire resistance time.

For the structural design of the wood beam, calculate the maximum induced moment.

Calculate beam load:

$$w_{total} = s (q_{dead} + q_{live}) = (6)(25 + 100) = 750 \text{ plf}$$

Calculate maximum induced moment:

$$M_{max} = w_{total} L^2 / 8 = (750)(18^2)/8 = 30,375 \text{ ft-lbs}$$

Select a $6\frac{3}{4}'' \times 13\frac{1}{2}''$ 24F visually-graded Douglas-fir glulam beam with a tabulated bending stress, F_b , equal to 2400 psi.

Calculate beam section modulus:

$$S_s = bd^2/6 = (6.75)(13.5)^2/6 = 205.0 \text{ in}^3$$

Calculate the adjusted allowable bending stress (assuming $C_D=1.0$: $C_M=1.0$: $C_t=1.0$: $C_L=1.0$: $C_V=0.98$)

$$F'_b = F_b (C_D)(C_M)(C_t)(\text{lesser of } C_L \text{ or } C_V) = 2400 (1.0)(1.0)(1.0)(0.98) = 2343 \text{ psi} \quad (\text{NDS 5.3.1})$$

Calculate design resisting moment:

$$M' = F'_b S_s = (2343)(205.0)/12 = 40,032 \text{ ft-lbs}$$

Structural Check: $M' \geq M_{max}$ **40,032 ft-lbs \geq 30,375 ft-lbs** ✓

For the fire design of the wood beam, the loading is unchanged. Therefore, the maximum induced moment is unchanged. The fire resistance must be calculated.

Calculate beam section modulus exposed on three-sides:

$$S_f = (b-2a)(d-a)^2/6 = (6.75-3.6)(13.5-1.8)^2/6 = 71.9 \text{ in}^3$$

Calculate the adjusted allowable bending stress (assuming $C_D=N/A$: $C_M=N/A$: $C_t=N/A$: $C_L=1.0$: $C_V=0.98$)

$$F'_b = F_b (\text{lesser of } C_L \text{ or } C_V) = 2400 (0.98) = 2343 \text{ psi} \quad (\text{NDS 5.3.1})$$

Calculate strength resisting moment:

$$M' = (2.85) F'_b S_f = (2.85)(2343)(71.9)/12 = 40,010 \text{ ft-lbs} \quad (\text{NDS 16.2.2})$$

Fire Check: $M' \geq M_{max}$ **40,010 ft-lbs \geq 30,375 ft-lbs** ✓

Design Aid (Appendix)

Calculate structural design load ratio:

$$r_s = M_{max}/M' = 30,375/40,032 = 0.76$$

Select the maximum design load ratio limit from Appendix Table 1B or calculate using the following equation:

$$R_s = \frac{2.85 S_f}{S_s C_D C_M C_t} = \frac{(2.85)(71.9)}{(205)(1.0)(1.0)(1.0)} = 1.00$$

Fire Check: $R_s \geq r_s$ **1.00 \geq 0.76** ✓

Exposed Column Example - Allowable Stress Design

A Southern pine glulam column with an effective column length, $\ell_e=168"$. The design loads are $P_{snow}=16000$ lbs. and $P_{dead}=6000$ lbs. Calculate the required section dimensions for a one-hour fire resistance time.

For the structural design of the wood column, calculate the maximum induced compression stress, f_c .

Calculate column load:

$$P_{total} = P_{dead} + P_{snow} = 8000 + 16000 = 22,000 \text{ lbs}$$

Select a $8\frac{1}{2}" \times 9\frac{5}{8}"$ Combination #48 Southern pine glulam column with a tabulated compression parallel-to-grain stress, F_c , equal to 2200 psi and a tabulated modulus of elasticity, E , equal to 1,700,000 psi.

Calculate column area:

$$A_s = bd = (9.625)(8.5) = 81.81 \text{ in}^2$$

$$I_s = bd^3/12 = (9.625)(8.5)^3/12 = 492.6 \text{ in}^4$$

Calculate the adjusted allowable compression stress (assuming $C_D=1.15$; $C_M=1.0$; $C_t=1.0$):

$$E' = E (C_M)(C_t) = 1,700,000 (1.0)(1.0) = 1,700,000 \text{ psi} \quad (\text{NDS 5.3.1})$$

$$F_{cE} = 0.418 E' / (\ell_e/d)^2 = 0.418 (1,700,000) / (168/8.5)^2 = 1819 \text{ psi} \quad (\text{NDS 3.7.1.5})$$

$$F_c^* = F_c (C_D)(C_M)(C_t) = 2200 (1.15)(1.0)(1.0) = 2530 \text{ psi} \quad (\text{NDS 3.7.1.5})$$

$$c = 0.9 \text{ for glued laminated timbers} \quad (\text{NDS 3.7.1.5})$$

$$\alpha_c = F_{cE}/F_c^* = 1819/2530 = 0.7190$$

$$C_p = \frac{1 + \alpha_c}{2c} - \sqrt{\left(\frac{1 + \alpha_c}{2c}\right)^2 - \frac{\alpha_c}{c}} = \frac{1 + 0.7190}{2(0.9)} - \sqrt{\left(\frac{1 + 0.7190}{2(0.9)}\right)^2 - \frac{0.7190}{0.9}} = 0.6186 \quad (\text{NDS 3.7.1.5})$$

$$F_c' = F_c^* (C_p) = 2530 (0.6186) = 1565 \text{ psi} \quad (\text{NDS 5.3.1})$$

Calculate the resisting column compression capacity:

$$P' = F_c' A_s = (1565)(81.81) = 128,043 \text{ lbs}$$

Structural Check: $P' \geq P_{load}$ **128,043 lbs \geq 22,000 lbs** ✓

For the fire design of the wood column, the loading is unchanged. Therefore, the total load is unchanged. The fire resistance must be calculated.

Calculate column area, A_f , and moment of inertia, I_f , for column exposed on four-sides:

$$A_f = (b-2a)(d-2a) = (9.625-3.6)(8.5-3.6) = 29.52 \text{ in}^2$$

$$I_f = (b-2a)(d-2a)^3/12 = (9.625-3.6)(8.5-3.6)^3/12 = 59.07 \text{ in}^4$$

Calculate the adjusted allowable compression stress (assuming $C_D=N/A$; $C_M=N/A$; $C_t=N/A$):

$$F_{cE} = (2.03) 0.418 E' / (\ell_e/d)^2 = (2.03)(0.418)(1,700,000) / (168/(8.5-3.6))^2 = 1227 \text{ psi} \quad (\text{NDS 16.2.2})$$

$$F_c^* = (2.58) F_c = (2.58)(2200) = 5676 \text{ psi ft-lbs} \quad (\text{NDS 16.2.2})$$

$$\alpha_c = F_{cE}/F_c^* = 1227/5676 = 0.2162$$

$$C_p = \frac{1 + 0.2162}{2(0.9)} - \sqrt{\left(\frac{1 + 0.2162}{2(0.9)}\right)^2 - \frac{0.2162}{0.9}} = 0.2106$$

$$F_c' = 5676 (0.2106) = 1195 \text{ psi}$$

Calculate the resisting column compression capacity:

$$P' = F_c' A_f = (1195)(29.52) = 35,280 \text{ lbs}$$

Fire Check: $P' \geq P_{load}$ **35,280 lbs \geq 22,000 lbs** ✓

Design Aid (Appendix)

Calculate structural design load ratio:

$$r_s = M_{\max}/M' = 22,000/128,043 = 0.17$$

Select the maximum design load ratio (buckling) limit from Appendix Table 5A or calculate using the following equation:

$$R_s = \frac{2.03 I_f}{I_s C_M C_t} = \frac{(2.03)(59.07)}{(492.6)(1.0)(1.0)} = 0.24$$

Fire Check:

$$R_s \geq r_s$$

$$0.24 \geq 0.17$$

✓

Exposed Tension Member Example - Allowable Stress Design

Solid sawn Hem-Fir timbers used as heavy timber truss webs. The total design tension loads from a roof live and dead load are $P_{total}=3,500$ lbs. Calculate the required section dimensions for a one-hour fire resistance time.

For the structural design of the wood timber, calculate the maximum induced tension stress, f_t .

Calculate tension load:

$$P_{total} = 3,500 \text{ lbs}$$

Select a nominal 6x6 (5½" x 5½") Hem-Fir #2 grade timber with a tabulated tension stress, F_t , equal to 375 psi.

Calculate timber area:

$$A_s = bd = (5.5)(5.5) = 30.25 \text{ in}^2$$

Calculate the adjusted allowable tension stress (assuming $C_D=1.25$: $C_M=1.0$: $C_t=1.0$):

$$F'_t = F_t (C_D)(C_M)(C_t) = 375 (1.25)(1.0)(1.0) = 469 \text{ psi} \quad (\text{NDS 4.3.1})$$

Calculate the resisting tension capacity:

$$P' = F'_c A_s = (469)(30.25) = 13,038 \text{ lbs}$$

Structural Check: $P' \geq P_{load}$ **14,180 lbs \geq 3,500 lbs** ✓

For the fire design of the timber tension member, the loading is unchanged. Therefore, the total load is unchanged. The fire resistance must be calculated.

Calculate tension member area, A , for member exposed on four-sides:

$$A_f = (b-2a)(d-2a) = (5.5-3.6)(5.5-3.6) = 3.61 \text{ in}^2$$

Calculate the adjusted allowable tension stress (assuming $C_D=N/A$: $C_M=N/A$: $C_t=N/A$):

$$F'_t = (2.85) F_t = (2.85)(375) = 1069 \text{ psi ft-lbs} \quad (\text{NDS 16.2.2})$$

Calculate the resisting tension capacity:

$$P' = F'_t A_f = (1069)(3.61) = 3,858 \text{ lbs}$$

Fire Check: $P' \geq P_{load}$ **3,858 lbs \geq 3,500 lbs** ✓

Design Aid (Appendix)

Calculate structural design load ratio:

$$r_s = M_{max}/M' = 3,500/14,180 = 0.25$$

Select the maximum design load ratio limit from Appendix Table 8C or calculate using the following equation:

$$R_s = \frac{2.85 A_f}{A_s C_D C_M C_t} = \frac{(2.85)(3.61)}{(30.25)(1.25)(1.0)(1.0)} = 0.27$$

Fire Check: $R_s \geq r_s$ **0.27 \geq 0.25** ✓

Exposed Deck Example - Allowable Stress Design

Hem-Fir tongue-and-groove timber decking spans $L=6'$. A single layer of 3/4" sheathing is installed over the decking. The design loads are $q_{\text{live}}=40$ psf and $q_{\text{dead}}=10$ psf.

Calculate deck load:

$$w_{\text{total}} = B(q_{\text{dead}} + q_{\text{live}}) = (5.5 \text{ in}/12 \text{ in/ft})(50 \text{ psf}) = 22.9 \text{ plf}$$

Calculate maximum induced moment:

$$M_{\text{max}} = w_{\text{total}} L^2 / 8 = (22.9)(6^2)/8 = 103 \text{ ft-lbs}$$

Select nominal 3x6 (2½" x 5½") Hem-Fir Commercial decking with a tabulated bending stress, F_b , equal to 1350 psi.

Calculate beam section modulus:

$$S_s = bd^2/6 = (5.5)(2.5)^2/6 = 5.73 \text{ in}^3$$

Calculate the adjusted allowable bending stress (assuming $C_D=1.0$: $C_M=1.0$: $C_t=1.0$: $C_F=1.04$):

$$F'_b = F_b (C_D)(C_M)(C_t)(C_F) = 1350 (1.0)(1.0)(1.0)(1.04) = 1404 \text{ psi} \quad (\text{NDS 4.3.1})$$

Calculate resisting moment:

$$M' = F'_b S_s = (1404)(5.73)/12 = 670 \text{ ft-lbs}$$

Structural Check: $M' \geq M_{\text{max}}$ **670 ft-lbs \geq 103 ft-lbs** ✓

For the fire design of the timber deck, the loading is unchanged. Therefore, the maximum induced moment is unchanged. The fire resistance must be calculated.

Calculate beam section modulus exposed on one-side:

$$S_f = (b)(d-a)^2/6 = (5.5)(2.5-1.8)^2/6 = 0.45 \text{ in}^3$$

Calculate the adjusted allowable bending stress (assuming $C_D=N/A$: $C_M=N/A$: $C_t=N/A$: $C_F=1.04$):

$$F'_b = F_b (C_F) = 1350 (1.04) = 1404 \text{ psi}$$

Calculate resisting moment:

$$M' = (2.85) F_b S_f = (2.85)(1404)(0.45)/12 = 150 \text{ ft-lbs} \quad (\text{NDS 16.2.2})$$

Fire Check: $M' \geq M_{\text{max}}$ **150 ft-lbs \geq 103 ft-lbs** ✓

Design Aid (Appendix)

Calculate structural design load ratio:

$$r_s = M_{\text{max}}/M' = 103/670 = 0.15$$

Select the maximum design load ratio limit from Appendix Table 9 or calculate using the following equation:

$$R_s = \frac{2.85 S_f}{S_s C_D C_M C_t} = \frac{(2.85)(0.45)}{(5.73)(1.0)(1.0)(1.0)} = 0.22$$

Fire Check: $R_s \geq r_s$ **0.22 \geq 0.15** ✓

REFERENCES

- [1] Malhotra, H., and Rogowski, F., "Fire-Resistance of Laminated Timber Columns," *Proceedings of Symposium No. 3*, Her Majesty's Stationary Office, London 1970, pp.16-51.
- [2] "ASTM E 119 - 88: Standard Test Methods for Fire Tests of Building Construction and Materials," in *ASTM Test Standards*, Philadelphia, PA, 1993, pp. 674-694.
- [3] "ISO 834: Fire-Resistance Tests - Elements of Building Construction," International Organization for Standardization, Geneva, Switzerland, 1975.
- [4] Lie, T.T., "A Method for Assessing the Fire Resistance of Laminated Timber Beams and Columns", *Canadian Journal of Civil Engineering*, Vol. 4, 1977, pp.161-169.
- [5] "Design of One-Hour Fire-Resistive Exposed Wood Members," Council of American Building Officials, National Evaluation Board Report No. NRB-250, 1984.
- [6] Fackler, J.P., *Cahiers du CSTB No. 52*, Centre Technique et Scientifique du Bâtiment, Paris, France, 1961.
- [7] Malhotra, H., and Rogowski, F., "Fire-Resistance of Laminated Timber Columns," *Proceedings of Symposium No. 3*, Her Majesty's Stationary Office, London 1970, pp. 16-51.
- [8] Stanke, J., Klement, E., and Rudolphi, R., "Das Brandverhalten von Holzstützen unter Druckbeanspruchung (The Fire Performance of Timber Columns under Compression Load)," *BAM-Berichte Nr. 24*, BAM, Berlin, 1973.
- [9] *2001 National Design Specification® for Wood Construction - ANSI/AF&PA NDS-2001*, American Forest & Paper Association, American Wood Council, Washington, DC, 2001.
- [10] *Eurocode 5, Part 1.2, Structural Fire Design*, CEN, Brussels, Belgium, 1994.
- [11] "AS 1720 Part 4: Fire Resistance of Structural Timber Members", Standard Association of Australia, North Sydney, Australia, 1985.
- [12] "Development of Firesafety Design Method of Buildings", Ministry of Construction Research Report, Tokyo, Japan, 1988.
- [13] King, E., and Glowinski, R., "A Rationalized Model for Calculating the Fire Endurance of Wood Beams", *Forest Products Journal*, Vol. 38, 1988, pp. 31-36.
- [14] Majamaa, J., "Calculation Models of Fire Exposed Wooden Beams", *Proceedings of the 1991 International Timber Engineering Conference*, Vol. 4, 1991, pp.91-98.
- [15] "ASTM D 245 - 93: Standard Practice for Establishing Structural Grades and Related Properties for Visually Graded Lumber," ASTM, Philadelphia, PA, 1993.
- [16] Hall, G., "Fire Resistance Tests of Laminated Timber Beams," Research Report WT/RR/1, Timber Research and Development Association, High Wycombe, UK, 1968.
- [17] "Report of Standard Fire Endurance Test - Nominal 8-³/₄" by 16-¹/₂" Glulam Wood Beam," Report No. WHI-694-0069, Warnock Hersey International Inc., Severna Park, MD, 1982.
- [18] Syme, D., "Verification of Charring Equations for Australian Timbers Based on Full-Scale Fire Resistance Tests," *Proceedings of the Pacific Timber Engineering Conference*, Gold Coast, Australia, 1994, pp. 619-623.
- [19] Ruger, F., Delafont, C., and El Ouadrani, A., "The Structural Properties of French-Grown Timber According to Various Grading Methods," *Proceedings of CIB W18 Meeting*, Paper #5.
- [20] "Plank and Beam Framing for Residential Buildings," National Forest Products Association, Washington, DC, 1989.
- [21] "Fire Resistance of Heavy Timber and Plywood Roof Constructions," Underwriters' Laboratories File NC495, Chicago, IL, 1964.
- [22] Bletzacker, R., Lane, W., and Denning, D., "Fire Resistance of Construction Assemblies - Volume I," Ohio State University, Columbus, OH, 1969.
- [23] "Evaluation of the Effects of Load on the Fire Resistance of Glulam Beams," SwRI Project No. 01-8641-001, Southwest Research Institute, San Antonio, TX, 1997.

- [24] White, Robert H., "Charring Rates of Different Wood Species," PhD Thesis, University of Wisconsin, Madison, WI, 1988.
- [25] "Standard for Load and Resistance Factor Design (LRFD) for Engineered Wood Construction - (AF&PA/ASCE 16-95)," American Society of Civil Engineers, New York, NY, 1995.
- [26] Dayeh, R.J. and Syme, D. R. "Behaviour of Glulam Beams in Fire," *Proceedings of Building the Future Seminar*, Institution of Structural Engineers, Brighton, United Kingdom, 1993.
- [27] White, Robert H., "Fire Endurance Tests of Axially Loaded Timber Tension Members," U.S. Forest Products Laboratory, U.S. Department of Agriculture, Madison, WI, 2001.

APPENDIX: Derivation of Load Ratio Tables

For members stressed in one principle direction, simplifications can be made which allow the tabulation of load factor tables. These load factor tables can be used to determine the structural design load ratio, R_s , at which the member has sufficient capacity for a given fire endurance time. This appendix provides the rational used to develop the load ratio tables provided later in this appendix. For more complex calculations where stress interactions must be considered, the user should consider using the provisions of this technical report with the appropriate *NDS* provisions.

Bending Members

$$\text{Structural: } D+L \leq R_s F_b S_s C_{L-s} C_D C_M C_t$$

$$\text{Fire: } D+L \leq 2.85 F_b S_f C_{L-f}$$

Where;

- D = Design dead load
- L = Design live load
- R_s = Design load ratio
- F_b = Tabulated bending design value
- S_s = Section modulus using full cross-section dimensions
- S_f = Section modulus using cross-section dimensions reduced from fire exposure
- C_{L-s} = Beam Stability factor using full cross-section dimensions
- C_{L-f} = Beam Stability factor using cross-section dimensions reduced from fire exposure
- C_D = Load Duration factor
- C_M = Wet Service factor
- C_t = Temperature factor

Solve for R_s :

$$R_s = \frac{2.85 S_f C_{L-f}}{S_s C_{L-s} C_D C_M C_t}$$

Load ratio tables were developed for standard reference conditions where: $C_D=1.0$; $C_M=1.0$; $C_t=1.0$; $C_{L-f}=1.0$

The calculation of C_{L-s} and C_{L-f} require the designer to consider both the change in bending section relative to bending strength and the change in buckling stiffness relative to buckling strength. While these relationships can be directly calculated using *NDS* provisions, they can not be easily tabulated. However, for most beams exposed on three-sides, the beams are braced on the protected side. For long span beams exposed on four-sides, the beam failure is influenced by buckling due to lateral instability. When buckling is considered, the following equations should be used:

$$\text{Structural (buckling): } D+L \leq R_s E_{05} I_{yy-s} / \ell_e C_M C_t$$

$$\text{Fire (buckling): } D+L \leq 2.03 E_{05} I_{yy-f} / \ell_e$$

Where;

- D = Design dead load
- L = Design live load
- R_s = Design load ratio (buckling)
- $E_{05} = (1.03) E_{\text{mean}} / 1.66 / (1-1.645 \text{ COV}_E)$
- E_{mean} = Tabulated modulus of elasticity
- COV_E = Coefficient of variation for modulus of elasticity
- I_{yy-s} = Lateral moment of inertia using full cross-section dimensions
- I_{yy-f} = Lateral moment of inertia using cross-section dimensions reduced from fire exposure

C_M = Wet Service factor
 C_t = Temperature factor

$$R_s = \frac{2.03 I_{yy-f}}{I_{yy-s} C_M C_t}$$

Compression Members

Structural: $D+L \leq R_s F_c C_{p-s} C_D C_M C_t$

Fire: $D+L \leq 2.58 F_c C_{p-f}$

Where;

D = Design dead load
 L = Design live load
 R_s = Design load ratio
 F_c = Tabulated compression parallel-to-grain design value
 C_{p-s} = Column stability factor using full cross-section dimensions
 C_{p-f} = Column stability factor using cross-section dimensions reduced from fire exposure
 C_D = Load Duration factor
 C_M = Wet Service factor
 C_t = Temperature factor

The calculation of C_{p-s} and C_{p-f} require the designer to consider both the change in compression area relative to compression parallel-to-grain strength and the change in buckling stiffness relative to buckling strength. While these relationships can be directly calculated using *NDS* provisions, they can not be easily tabulated. However, for most column fire endurance designs the mode of column failure is significantly influenced by buckling. For this reason, conservative load ratio tables can be tabulated for changes in buckling capacity as a function of fire exposure.

Structural (buckling): $D+L \leq R_s \pi^2 E_{05} I_s / \ell_e^2 C_M C_t$

Fire (buckling): $D+L \leq 2.03 \pi^2 E_{05} I_f / \ell_e^2$

Where;

D = Design dead load
 L = Design live load
 R_s = Design load ratio (buckling)
 $E_{05} = (1.03) E_{\text{mean}} / 1.66 / (1-1.645 \text{ COV}_E)$
 E_{mean} = Tabulated modulus of elasticity
 COV_E = Coefficient of variation for modulus of elasticity
 I_s = Moment of inertia using full cross-section dimensions
 I_f = Moment of inertia using cross-section dimensions reduced from fire exposure
 C_M = Wet Service factor
 C_t = Temperature factor

$$R_s = \frac{2.03 I_f}{I_s C_M C_t}$$

Buckling load ratio tables were developed for standard reference conditions where: $C_M=1.0$; $C_t=1.0$

NOTE: The load duration factor, C_D , is not included in the load ratio tables since modulus of elasticity values, E , used in the buckling capacity calculation is not adjusted for load duration in the *NDS*.

Tension Members

$$\text{Structural: } D+L \leq R_s F_t A_s C_D C_M C_t C_i$$

$$\text{Fire: } D+L \leq 2.85 F_t A_f$$

Where;

D = Design dead load

L = Design live load

R_s = Design load ratio

F_t = Tabulated tension parallel-to-grain design value

A_s = Area of cross-section using full cross-section dimensions

A_f = Area of cross-section using cross-section dimensions reduced from fire exposure

C_D = Load Duration factor

C_M = Wet Service factor

C_t = Temperature factor

$$R_s = \frac{2.85 A_f}{A_s C_D C_M C_t}$$

Load ratio tables were developed for standard reference conditions where: $C_D=1.0$; $C_M=1.0$; $C_t=1.0$

Design Load Ratios for Bending Members Exposed on Three Sides
 (Structural Calculations at Standard Reference Conditions: C_D=1.0, C_M=1.0, C_t=1.0, C_i=1.0, C_L=1.0)
 (Protected Surface in Depth Direction)

Table 1A. Southern Pine Glued Laminated Timbers

Rating	1-HOUR				1.5-HOUR			2-HOUR		
	Beam Width	5	6.75	8.5	10.5	6.75	8.5	10.5	8.5	10.5
Beam Depth	Design Load Ratio, R _s									
5.5	0.36	0.60	0.74	0.85	0.22	0.35	0.44	0.13	0.20	
6.875	0.43	0.72	0.90	1.00	0.30	0.47	0.60	0.21	0.33	
8.25	0.49	0.81	1.00	1.00	0.36	0.57	0.72	0.28	0.43	
9.625	0.53	0.88	1.00	1.00	0.40	0.64	0.82	0.33	0.51	
11	0.56	0.93	1.00	1.00	0.44	0.70	0.89	0.37	0.58	
12.375	0.58	0.97	1.00	1.00	0.47	0.75	0.95	0.40	0.63	
13.75	0.60	1.00	1.00	1.00	0.49	0.78	1.00	0.43	0.67	
15.125	0.62	1.00	1.00	1.00	0.51	0.82	1.00	0.46	0.71	
16.5	0.63	1.00	1.00	1.00	0.53	0.84	1.00	0.48	0.74	
17.875	0.65	1.00	1.00	1.00	0.54	0.87	1.00	0.49	0.77	
19.25	0.66	1.00	1.00	1.00	0.56	0.89	1.00	0.51	0.79	
20.625	0.66	1.00	1.00	1.00	0.57	0.90	1.00	0.52	0.81	
22	0.67	1.00	1.00	1.00	0.58	0.92	1.00	0.53	0.83	
23.375	0.68	1.00	1.00	1.00	0.59	0.93	1.00	0.55	0.85	
24.75	0.69	1.00	1.00	1.00	0.60	0.95	1.00	0.55	0.86	
26.125	0.69	1.00	1.00	1.00	0.60	0.96	1.00	0.56	0.88	
27.5	0.70	1.00	1.00	1.00	0.61	0.97	1.00	0.57	0.89	
28.875	0.70	1.00	1.00	1.00	0.61	0.98	1.00	0.58	0.90	
30.25	0.71	1.00	1.00	1.00	0.62	0.99	1.00	0.58	0.91	
31.625	0.71	1.00	1.00	1.00	0.62	0.99	1.00	0.59	0.92	
33	0.71	1.00	1.00	1.00	0.63	1.00	1.00	0.60	0.93	
34.375	0.72	1.00	1.00	1.00	0.63	1.00	1.00	0.60	0.93	
35.75	0.72	1.00	1.00	1.00	0.64	1.00	1.00	0.61	0.94	
37.125	1.00	1.00	1.00	1.00	0.64	1.00	1.00	0.61	0.95	
38.5	1.00	1.00	1.00	1.00	0.64	1.00	1.00	0.61	0.95	
39.875	1.00	1.00	1.00	1.00	0.65	1.00	1.00	0.62	0.96	
41.25	1.00	1.00	1.00	1.00	0.65	1.00	1.00	0.62	0.97	
42.625	1.00	1.00	1.00	1.00	0.65	1.00	1.00	0.63	0.97	
44	1.00	1.00	1.00	1.00	0.66	1.00	1.00	0.63	0.98	
45.375	1.00	1.00	1.00	1.00	0.66	1.00	1.00	0.63	0.98	
46.75	1.00	1.00	1.00	1.00	0.66	1.00	1.00	0.63	0.99	
48.125	1.00	1.00	1.00	1.00	0.66	1.00	1.00	0.64	0.99	
49.5	1.00	1.00	1.00	1.00	1.00	1.00	1.00	0.64	0.99	
50.875	1.00	1.00	1.00	1.00	1.00	1.00	1.00	0.64	1.00	
52.25	1.00	1.00	1.00	1.00	1.00	1.00	1.00	0.64	1.00	
53.625	1.00	1.00	1.00	1.00	1.00	1.00	1.00	0.65	1.00	
55	1.00	1.00	1.00	1.00	1.00	1.00	1.00	0.65	1.00	
56.375	1.00	1.00	1.00	1.00	1.00	1.00	1.00	0.65	1.00	
57.75	1.00	1.00	1.00	1.00	1.00	1.00	1.00	0.65	1.00	
59.125	1.00	1.00	1.00	1.00	1.00	1.00	1.00	0.65	1.00	
60.5	1.00	1.00	1.00	1.00	1.00	1.00	1.00	0.66	1.00	
61.875	1.00	1.00	1.00	1.00	1.00	1.00	1.00	0.66	1.00	
63.25	1.00	1.00	1.00	1.00	1.00	1.00	1.00	0.66	1.00	
64.625	1.00	1.00	1.00	1.00	1.00	1.00	1.00	1.00	1.00	
66	1.00	1.00	1.00	1.00	1.00	1.00	1.00	1.00	1.00	
67.375	1.00	1.00	1.00	1.00	1.00	1.00	1.00	1.00	1.00	
68.75	1.00	1.00	1.00	1.00	1.00	1.00	1.00	1.00	1.00	
70.125	1.00	1.00	1.00	1.00	1.00	1.00	1.00	1.00	1.00	
71.5	1.00	1.00	1.00	1.00	1.00	1.00	1.00	1.00	1.00	
72.875	1.00	1.00	1.00	1.00	1.00	1.00	1.00	1.00	1.00	
74.25	1.00	1.00	1.00	1.00	1.00	1.00	1.00	1.00	1.00	
75.625	1.00	1.00	1.00	1.00	1.00	1.00	1.00	1.00	1.00	
77	1.00	1.00	1.00	1.00	1.00	1.00	1.00	1.00	1.00	

Table 1B. Western Species Glued Laminated Timbers

Rating	1-HOUR				1.5-HOUR			2-HOUR		
	Beam Width	5.13	6.75	8.75	10.8	6.75	8.75	10.8	8.75	10.8
Beam Depth	Design Load Ratio, R _s									
6	0.42	0.65	0.82	0.93	0.25	0.41	0.52	0.18	0.26	
7.5	0.49	0.77	0.97	1.00	0.33	0.54	0.68	0.26	0.39	
9	0.54	0.85	1.00	1.00	0.38	0.64	0.79	0.33	0.49	
10.5	0.58	0.91	1.00	1.00	0.43	0.71	0.88	0.39	0.57	
12	0.61	0.96	1.00	1.00	0.46	0.76	0.95	0.43	0.64	
13.5	0.64	1.00	1.00	1.00	0.49	0.81	1.00	0.46	0.69	
15	0.66	1.00	1.00	1.00	0.51	0.85	1.00	0.49	0.73	
16.5	0.67	1.00	1.00	1.00	0.53	0.88	1.00	0.52	0.77	
18	0.69	1.00	1.00	1.00	0.55	0.90	1.00	0.54	0.80	
19.5	0.70	1.00	1.00	1.00	0.56	0.93	1.00	0.55	0.82	
21	0.71	1.00	1.00	1.00	0.57	0.95	1.00	0.57	0.85	
22.5	0.72	1.00	1.00	1.00	0.58	0.96	1.00	0.58	0.87	
24	0.73	1.00	1.00	1.00	0.59	0.98	1.00	0.60	0.88	
25.5	0.73	1.00	1.00	1.00	0.60	0.99	1.00	0.61	0.90	
27	0.74	1.00	1.00	1.00	0.61	1.00	1.00	0.62	0.91	
28.5	0.74	1.00	1.00	1.00	0.61	1.00	1.00	0.62	0.93	
30	0.75	1.00	1.00	1.00	0.62	1.00	1.00	0.63	0.94	
31.5	0.75	1.00	1.00	1.00	0.62	1.00	1.00	0.64	0.95	
33	0.76	1.00	1.00	1.00	0.63	1.00	1.00	0.65	0.96	
34.5	0.76	1.00	1.00	1.00	0.63	1.00	1.00	0.65	0.97	
36	0.77	1.00	1.00	1.00	0.64	1.00	1.00	0.66	0.98	
37.5	1.00	1.00	1.00	1.00	0.64	1.00	1.00	0.66	0.98	
39	1.00	1.00	1.00	1.00	0.64	1.00	1.00	0.67	0.99	
40.5	1.00	1.00	1.00	1.00	0.65	1.00	1.00	0.67	1.00	
42	1.00	1.00	1.00	1.00	0.65	1.00	1.00	0.68	1.00	
43.5	1.00	1.00	1.00	1.00	0.65	1.00	1.00	0.68	1.00	
45	1.00	1.00	1.00	1.00	0.66	1.00	1.00	0.68	1.00	
46.5	1.00	1.00	1.00	1.00	0.66	1.00	1.00	0.69	1.00	
48	1.00	1.00	1.00	1.00	0.66	1.00	1.00	0.69	1.00	
49.5	1.00	1.00	1.00	1.00	1.00	1.00	1.00	0.69	1.00	
51	1.00	1.00	1.00	1.00	1.00	1.00	1.00	0.70	1.00	
52.5	1.00	1.00	1.00	1.00	1.00	1.00	1.00	0.70	1.00	
54	1.00	1.00	1.00	1.00	1.00	1.00	1.00	0.70	1.00	
55.5	1.00	1.00	1.00	1.00	1.00	1.00	1.00	0.70	1.00	
57	1.00	1.00	1.00	1.00	1.00	1.00	1.00	0.70	1.00	
58.5	1.00	1.00	1.00	1.00	1.00	1.00	1.00	0.71	1.00	
60	1.00	1.00	1.00	1.00	1.00	1.00	1.00	0.71	1.00	
61.5	1.00	1.00	1.00	1.00	1.00	1.00	1.00	0.71	1.00	
63	1.00	1.00	1.00	1.00	1.00	1.00	1.00	0.71	1.00	
64.5	1.00	1.00	1.00	1.00	1.00	1.00	1.00	1.00	1.00	
66	1.00	1.00	1.00	1.00	1.00	1.00	1.00	1.00	1.00	
67.5	1.00	1.00	1.00	1.00	1.00	1.00	1.00	1.00	1.00	
69	1.00	1.00	1.00	1.00	1.00	1.00	1.00	1.00	1.00	
70.5	1.00	1.00	1.00	1.00	1.00	1.00	1.00	1.00	1.00	
72	1.00	1.00	1.00	1.00	1.00	1.00	1.00	1.00	1.00	
73.5	1.00	1.00	1.00	1.00	1.00	1.00	1.00	1.00	1.00	
75	1.00	1.00	1.00	1.00	1.00	1.00	1.00	1.00	1.00	
76.5	1.00	1.00	1.00	1.00	1.00	1.00	1.00	1.00	1.00	
78	1.00	1.00	1.00	1.00	1.00	1.00	1.00	1.00	1.00	
79.5	1.00	1.00	1.00	1.00	1.00	1.00	1.00	1.00	1.00	
81	1.00	1.00	1.00	1.00	1.00	1.00	1.00	1.00	1.00	

Note: 1. Tabulated values assume bending in the depth direction.

Table 1C. Solid Sawn Timbers

Rating	1-HOUR				1.5-HOUR			2-HOUR		
	Beam Width	5.5	7.5	9.5	11.5	7.5	9.5	11.5	9.5	11.5
Beam Depth	Design Load Ratio, R _s									
5.5	0.45	0.67	0.80	0.89	0.28	0.40	0.48	0.17	0.23	
7.5	0.57	0.86	1.00	1.00	0.42	0.60	0.71	0.32	0.43	
9.5	0.65	0.97	1.00	1.00	0.51	0.73	0.87	0.42	0.57	
11.5	0.70	1.00	1.00	1.00	0.58	0.83	0.99	0.50	0.67	
13.5	0.74	1.00	1.00	1.00	0.63	0.89	1.00	0.56	0.75	
15.5	0.77	1.00	1.00	1.00	0.67	0.95	1.00	0.60	0.81	
17.5	0.79	1.00	1.00	1.00	0.70	0.99	1.00	0.64	0.86	
19.5	0.81	1.00	1.00	1.00	0.72	1.00	1.00	0.67	0.90	
21.5	0.83	1.00	1.00	1.00	0.74	1.00	1.00	0.69	0.93	
23.5	0.84	1.00	1.00</							

Design Load Ratios for Bending Members Exposed on Four Sides
 (Structural Calculations at Standard Reference Conditions: C_D=1.0, C_M=1.0, C_t=1.0, C_i=1.0, C_L=1.0)

Table 2A. Southern Pine Glued Laminated Timbers

Rating	1-HOUR				1.5-HOUR			2-HOUR	
	5	6.75	8.5	10.5	6.75	8.5	10.5	8.5	10.5
Beam Width	Design Load Ratio, R _s								
Beam Depth	Design Load Ratio, R _s								
5.5	0.10	0.16	0.20	0.22	0.01	0.01	0.01	0.02	0.03
6.875	0.18	0.30	0.37	0.42	0.05	0.09	0.11	0.00	0.01
8.25	0.25	0.42	0.52	0.59	0.11	0.18	0.23	0.04	0.06
9.625	0.31	0.52	0.64	0.73	0.17	0.27	0.34	0.09	0.13
11	0.36	0.60	0.74	0.85	0.22	0.35	0.44	0.13	0.20
12.375	0.40	0.67	0.83	0.94	0.26	0.42	0.53	0.17	0.27
13.75	0.43	0.72	0.90	1.00	0.30	0.47	0.60	0.21	0.33
15.125	0.46	0.77	0.95	1.00	0.33	0.52	0.67	0.25	0.38
16.5	0.49	0.81	1.00	1.00	0.36	0.57	0.72	0.28	0.43
17.875	0.51	0.85	1.00	1.00	0.38	0.61	0.77	0.30	0.47
19.25	0.53	0.88	1.00	1.00	0.40	0.64	0.82	0.33	0.51
20.625	0.54	0.91	1.00	1.00	0.42	0.67	0.86	0.35	0.54
22	0.56	0.93	1.00	1.00	0.44	0.70	0.89	0.37	0.58
23.375	0.57	0.95	1.00	1.00	0.45	0.72	0.92	0.39	0.60
24.75	0.58	0.97	1.00	1.00	0.47	0.75	0.95	0.40	0.63
26.125	0.59	0.99	1.00	1.00	0.48	0.77	0.97	0.42	0.65
27.5	0.60	1.00	1.00	1.00	0.49	0.78	1.00	0.43	0.67
28.875	0.61	1.00	1.00	1.00	0.50	0.80	1.00	0.44	0.69
30.25	0.62	1.00	1.00	1.00	0.51	0.82	1.00	0.46	0.71
31.625	0.63	1.00	1.00	1.00	0.52	0.83	1.00	0.47	0.73
33	0.63	1.00	1.00	1.00	0.53	0.84	1.00	0.48	0.74
34.375	0.64	1.00	1.00	1.00	0.54	0.86	1.00	0.49	0.75
35.75	0.65	1.00	1.00	1.00	0.54	0.87	1.00	0.49	0.77
37.125	1.00	1.00	1.00	1.00	0.55	0.88	1.00	0.50	0.78
38.5	1.00	1.00	1.00	1.00	0.56	0.89	1.00	0.51	0.79
39.875	1.00	1.00	1.00	1.00	0.56	0.90	1.00	0.52	0.80
41.25	1.00	1.00	1.00	1.00	0.57	0.90	1.00	0.52	0.81
42.625	1.00	1.00	1.00	1.00	0.57	0.91	1.00	0.53	0.82
44	1.00	1.00	1.00	1.00	0.58	0.92	1.00	0.53	0.83
45.375	1.00	1.00	1.00	1.00	0.58	0.93	1.00	0.54	0.84
46.75	1.00	1.00	1.00	1.00	0.59	0.93	1.00	0.55	0.85
48.125	1.00	1.00	1.00	1.00	0.59	0.94	1.00	0.55	0.85
49.5	1.00	1.00	1.00	1.00	0.95	1.00	1.00	0.55	0.86
50.875	1.00	1.00	1.00	1.00	0.95	1.00	1.00	0.56	0.87
52.25	1.00	1.00	1.00	1.00	0.96	1.00	1.00	0.56	0.88
53.625	1.00	1.00	1.00	1.00	0.96	1.00	1.00	0.57	0.88
55	1.00	1.00	1.00	1.00	0.97	1.00	1.00	0.57	0.89
56.375	1.00	1.00	1.00	1.00	0.97	1.00	1.00	0.57	0.89
57.75	1.00	1.00	1.00	1.00	0.98	1.00	1.00	0.58	0.90
59.125	1.00	1.00	1.00	1.00	0.98	1.00	1.00	0.58	0.90
60.5	1.00	1.00	1.00	1.00	0.99	1.00	1.00	0.58	0.91
61.875	1.00	1.00	1.00	1.00	0.99	1.00	1.00	0.59	0.91
63.25	1.00	1.00	1.00	1.00	0.99	1.00	1.00	0.59	0.92
64.625	1.00	1.00	1.00	1.00	1.00	1.00	1.00	0.92	0.92
66	1.00	1.00	1.00	1.00	1.00	1.00	1.00	0.93	0.93
67.375	1.00	1.00	1.00	1.00	1.00	1.00	1.00	0.93	0.93
68.75	1.00	1.00	1.00	1.00	1.00	1.00	1.00	0.93	0.93
70.125	1.00	1.00	1.00	1.00	1.00	1.00	1.00	0.94	0.94
71.5	1.00	1.00	1.00	1.00	1.00	1.00	1.00	0.94	0.94
72.875	1.00	1.00	1.00	1.00	1.00	1.00	1.00	0.95	0.95
74.25	1.00	1.00	1.00	1.00	1.00	1.00	1.00	0.95	0.95
75.625	1.00	1.00	1.00	1.00	1.00	1.00	1.00	0.95	0.95
77	1.00	1.00	1.00	1.00	1.00	1.00	1.00	0.95	0.95

Table 2B. Western Species Glued Laminated Timbers

Rating	1-HOUR				1.5-HOUR			2-HOUR	
	5.13	6.75	8.75	10.8	6.75	8.75	10.8	8.75	10.8
Beam Width	Design Load Ratio, R _s								
Beam Depth	Design Load Ratio, R _s								
6	0.14	0.21	0.27	0.30	0.02	0.03	0.04	0.00	0.00
7.5	0.23	0.36	0.45	0.51	0.08	0.13	0.17	0.02	0.03
9	0.31	0.48	0.60	0.68	0.15	0.24	0.30	0.07	0.10
10.5	0.37	0.57	0.72	0.82	0.20	0.33	0.42	0.12	0.19
12	0.42	0.65	0.82	0.93	0.25	0.41	0.52	0.18	0.26
13.5	0.46	0.72	0.90	1.00	0.29	0.48	0.60	0.22	0.33
15	0.49	0.77	0.97	1.00	0.33	0.54	0.68	0.26	0.39
16.5	0.52	0.81	1.00	1.00	0.36	0.59	0.74	0.30	0.45
18	0.54	0.85	1.00	1.00	0.38	0.64	0.79	0.33	0.49
19.5	0.56	0.88	1.00	1.00	0.41	0.67	0.84	0.36	0.54
21	0.58	0.91	1.00	1.00	0.43	0.71	0.88	0.39	0.57
22.5	0.60	0.94	1.00	1.00	0.45	0.74	0.92	0.41	0.61
24	0.61	0.96	1.00	1.00	0.46	0.76	0.95	0.43	0.64
25.5	0.63	0.98	1.00	1.00	0.48	0.79	0.98	0.45	0.66
27	0.64	1.00	1.00	1.00	0.49	0.81	1.00	0.46	0.69
28.5	0.65	1.00	1.00	1.00	0.50	0.83	1.00	0.48	0.71
30	0.66	1.00	1.00	1.00	0.51	0.85	1.00	0.49	0.73
31.5	0.67	1.00	1.00	1.00	0.52	0.86	1.00	0.50	0.75
33	0.67	1.00	1.00	1.00	0.53	0.88	1.00	0.52	0.77
34.5	0.68	1.00	1.00	1.00	0.54	0.89	1.00	0.53	0.78
36	0.69	1.00	1.00	1.00	0.55	0.90	1.00	0.54	0.80
37.5	1.00	1.00	1.00	1.00	0.55	0.92	1.00	0.55	0.81
39	1.00	1.00	1.00	1.00	0.56	0.93	1.00	0.55	0.82
40.5	1.00	1.00	1.00	1.00	0.57	0.94	1.00	0.56	0.84
42	1.00	1.00	1.00	1.00	0.57	0.95	1.00	0.57	0.85
43.5	1.00	1.00	1.00	1.00	0.58	0.96	1.00	0.58	0.86
45	1.00	1.00	1.00	1.00	0.58	0.96	1.00	0.58	0.87
46.5	1.00	1.00	1.00	1.00	0.59	0.97	1.00	0.59	0.88
48	1.00	1.00	1.00	1.00	0.59	0.98	1.00	0.60	0.88
49.5	1.00	1.00	1.00	1.00	0.99	1.00	1.00	0.60	0.89
51	1.00	1.00	1.00	1.00	0.99	1.00	1.00	0.61	0.90
52.5	1.00	1.00	1.00	1.00	1.00	1.00	1.00	0.61	0.91
54	1.00	1.00	1.00	1.00	1.00	1.00	1.00	0.62	0.91
55.5	1.00	1.00	1.00	1.00	1.00	1.00	1.00	0.62	0.92
57	1.00	1.00	1.00	1.00	1.00	1.00	1.00	0.62	0.93
58.5	1.00	1.00	1.00	1.00	1.00	1.00	1.00	0.63	0.93
60	1.00	1.00	1.00	1.00	1.00	1.00	1.00	0.63	0.94
61.5	1.00	1.00	1.00	1.00	1.00	1.00	1.00	0.64	0.94
63	1.00	1.00	1.00	1.00	1.00	1.00	1.00	0.64	0.95
64.5	1.00	1.00	1.00	1.00	1.00	1.00	1.00	0.95	0.95
66	1.00	1.00	1.00	1.00	1.00	1.00	1.00	0.96	0.96
67.5	1.00	1.00	1.00	1.00	1.00	1.00	1.00	0.96	0.96
69	1.00	1.00	1.00	1.00	1.00	1.00	1.00	0.97	0.97
70.5	1.00	1.00	1.00	1.00	1.00	1.00	1.00	0.97	0.97
72	1.00	1.00	1.00	1.00	1.00	1.00	1.00	0.98	0.98
73.5	1.00	1.00	1.00	1.00	1.00	1.00	1.00	0.98	0.98
75	1.00	1.00	1.00	1.00	1.00	1.00	1.00	0.98	0.98
76.5	1.00	1.00	1.00	1.00	1.00	1.00	1.00	0.99	0.99
78	1.00	1.00	1.00	1.00	1.00	1.00	1.00	0.99	0.99
79.5	1.00	1.00	1.00	1.00	1.00	1.00	1.00	0.99	0.99
81	1.00	1.00	1.00	1.00	1.00	1.00	1.00	1.00	1.00

Note: 1. Tabulated values assume bending in the depth direction.

Table 2C. Solid Sawn Timbers

Rating	1-HOUR				1.5-HOUR			2-HOUR	
	5.5	7.5	9.5	11.5	7.5	9.5	11.5	9.5	11.5
Beam Width	Design Load Ratio, R _s								
Beam Depth	Design Load Ratio, R _s								
5.5	0.12	0.18	0.21	0.23	0.01	0.01	0.01	0.02	0.03
7.5	0.27	0.40	0.48	0.53	0.10	0.15	0.18	0.02	0.03
9.5	0.38	0.57	0.68	0.76	0.21	0.30	0.36	0.11	0.14
11.5	0.46	0.70	0.84	0.92	0.30	0.43	0.51	0.19	0.26
13.5	0.53	0.80	0.95	1.00	0.38	0.53	0.64	0.27	0.36
15.5	0.58	0.87	1.00	1.00	0.43	0.62	0.74	0.33	0.45
17.5	0.62	0.93	1.00	1.00	0.48	0.69	0.82	0.39	0.52
19.5	0.65	0.99	1.00	1.00	0.52	0.74	0.89	0.43	0.59
21.5	0.68	1.00	1.00	1.00	0.56	0.79	0.95	0.47	0.64
23.5	0.71	1.00	1.00	1.00	0.59	0.84	1.00	0.51	0.69

Design Load Ratios for Compression Members Exposed on Three Sides
(Structural Calculations at Standard Reference Conditions: C_M=1.0, C_t=1.0, C_i=1.0)
(Protected Surface in Depth Direction)

Table 3A. Southern Pine Glued Laminated Timbers

Rating	1-HOUR			1.5-HOUR			2-HOUR			
	Col. Width	5	6.75	8.5	10.5	6.75	8.5	10.5	8.5	10.5
Col. Depth	Design Load Ratio, R _s									
5.5	0.03									
6.875	0.03	0.15			0.02					
8.25	0.03	0.16	0.30		0.02	0.10		0.02		
9.625	0.04	0.17	0.32	0.47	0.03	0.10	0.22	0.02	0.09	
11	0.04	0.17	0.33	0.48	0.03	0.11	0.22	0.02	0.09	
12.375	0.04	0.18	0.33	0.49	0.03	0.11	0.23	0.03	0.10	
13.75	0.04	0.18	0.34	0.50	0.03	0.12	0.24	0.03	0.10	
15.125	0.04	0.18	0.34	0.51	0.03	0.12	0.24	0.03	0.10	
16.5	0.04	0.18	0.35	0.51	0.03	0.12	0.25	0.03	0.10	
17.875	0.04	0.19	0.35	0.52	0.03	0.12	0.25	0.03	0.11	
19.25	0.04	0.19	0.35	0.52	0.03	0.12	0.25	0.03	0.11	
20.625	0.04	0.19	0.35	0.53	0.03	0.12	0.26	0.03	0.11	
22	0.04	0.19	0.36	0.53	0.03	0.12	0.26	0.03	0.11	
23.375	0.04	0.19	0.36	0.53	0.03	0.13	0.26	0.03	0.11	
24.75	0.04	0.19	0.36	0.53	0.03	0.13	0.26	0.03	0.11	
26.125	0.04	0.19	0.36	0.54	0.03	0.13	0.26	0.03	0.11	
27.5	0.04	0.19	0.36	0.54	0.03	0.13	0.26	0.03	0.11	
28.875	0.04	0.19	0.36	0.54	0.03	0.13	0.27	0.03	0.11	
30.25	0.04	0.19	0.37	0.54	0.03	0.13	0.27	0.03	0.11	
31.625	0.04	0.19	0.37	0.54	0.03	0.13	0.27	0.03	0.11	
33	0.04	0.20	0.37	0.54	0.03	0.13	0.27	0.03	0.12	
34.375	0.04	0.20	0.37	0.55	0.03	0.13	0.27	0.03	0.12	
35.75	0.04	0.20	0.37	0.55	0.03	0.13	0.27	0.03	0.12	
37.125	0.04	0.20	0.37	0.55	0.03	0.13	0.27	0.03	0.12	
38.5	0.04	0.20	0.37	0.55	0.03	0.13	0.27	0.03	0.12	
39.875	0.04	0.20	0.37	0.55	0.03	0.13	0.27	0.03	0.12	
41.25	0.04	0.20	0.37	0.55	0.03	0.13	0.27	0.03	0.12	
42.625	0.04	0.20	0.37	0.55	0.03	0.13	0.27	0.03	0.12	
44	0.04	0.20	0.37	0.55	0.03	0.13	0.27	0.03	0.12	
45.375	0.04	0.20	0.37	0.55	0.03	0.13	0.27	0.03	0.12	
46.75	0.04	0.20	0.37	0.55	0.03	0.13	0.28	0.03	0.12	
48.125	0.04	0.20	0.37	0.55	0.03	0.13	0.28	0.03	0.12	
49.5	0.04	0.20	0.37	0.55	0.03	0.13	0.28	0.03	0.12	
50.875	0.04	0.20	0.37	0.55	0.03	0.13	0.28	0.03	0.12	
52.25	0.04	0.20	0.37	0.55	0.03	0.13	0.28	0.03	0.12	
53.625	0.04	0.20	0.37	0.55	0.03	0.13	0.28	0.03	0.12	
55	0.04	0.20	0.37	0.55	0.03	0.13	0.28	0.03	0.12	
56.375	0.04	0.20	0.37	0.55	0.03	0.13	0.28	0.03	0.12	
57.75	0.04	0.20	0.37	0.55	0.03	0.13	0.28	0.03	0.12	
59.125	0.04	0.20	0.37	0.55	0.03	0.13	0.28	0.03	0.12	
60.5	0.04	0.20	0.37	0.55	0.03	0.13	0.28	0.03	0.12	
61.875	0.04	0.20	0.37	0.55	0.03	0.13	0.28	0.03	0.12	
63.25	0.04	0.20	0.37	0.55	0.03	0.13	0.28	0.03	0.12	
64.625	0.04	0.20	0.37	0.55	0.03	0.13	0.28	0.03	0.12	
66	0.04	0.20	0.37	0.55	0.03	0.13	0.28	0.03	0.12	
67.375	0.04	0.20	0.37	0.55	0.03	0.13	0.28	0.03	0.12	
68.75	0.04	0.20	0.37	0.55	0.03	0.13	0.28	0.03	0.12	
70.125	0.04	0.20	0.37	0.55	0.03	0.13	0.28	0.03	0.12	
71.5	0.04	0.20	0.37	0.55	0.03	0.13	0.28	0.03	0.12	
72.875	0.04	0.20	0.37	0.55	0.03	0.13	0.28	0.03	0.12	
74.25	0.04	0.20	0.37	0.55	0.03	0.13	0.28	0.03	0.12	
75.625	0.04	0.20	0.37	0.55	0.03	0.13	0.28	0.03	0.12	
77	0.04	0.20	0.37	0.55	0.03	0.13	0.28	0.03	0.12	

Table 3B. Western Species Glued Laminated Timbers

Rating	1-HOUR				1.5-HOUR			2-HOUR		
	Col. Width	5.125	6.75	8.75	10.75	6.75	8.5	10.5	8.75	10.75
Col. Depth	Design Load Ratio, R _s									
6	0.04									
7.5	0.04	0.16			0.02					
9	0.04	0.17	0.33		0.03	0.10		0.03		
10.5	0.04	0.17	0.34	0.49	0.03	0.11	0.22	0.03	0.10	
12	0.05	0.18	0.35	0.51	0.03	0.11	0.23	0.03	0.10	
13.5	0.05	0.18	0.36	0.52	0.03	0.11	0.24	0.03	0.11	
15	0.05	0.18	0.36	0.53	0.03	0.12	0.24	0.03	0.11	
16.5	0.05	0.18	0.37	0.53	0.03	0.12	0.25	0.03	0.11	
18	0.05	0.19	0.37	0.54	0.03	0.12	0.25	0.04	0.12	
19.5	0.05	0.19	0.38	0.54	0.03	0.12	0.25	0.04	0.12	
21	0.05	0.19	0.38	0.55	0.03	0.12	0.26	0.04	0.12	
22.5	0.05	0.19	0.38	0.55	0.03	0.13	0.26	0.04	0.12	
24	0.05	0.19	0.38	0.55	0.03	0.13	0.26	0.04	0.12	
25.5	0.05	0.19	0.38	0.56	0.03	0.13	0.26	0.04	0.12	
27	0.05	0.19	0.39	0.56	0.03	0.13	0.26	0.04	0.13	
28.5	0.05	0.19	0.39	0.56	0.03	0.13	0.27	0.04	0.13	
30	0.05	0.19	0.39	0.56	0.03	0.13	0.27	0.04	0.13	
31.5	0.05	0.19	0.39	0.56	0.03	0.13	0.27	0.04	0.13	
33	0.05	0.20	0.39	0.56	0.03	0.13	0.27	0.04	0.13	
34.5	0.05	0.20	0.39	0.57	0.03	0.13	0.27	0.04	0.13	
36	0.05	0.20	0.39	0.57	0.03	0.13	0.27	0.04	0.13	
37.5	0.05	0.20	0.39	0.57	0.03	0.13	0.27	0.04	0.13	
39	0.05	0.20	0.39	0.57	0.03	0.13	0.27	0.04	0.13	
40.5	0.05	0.20	0.40	0.57	0.03	0.13	0.27	0.04	0.13	
42	0.05	0.20	0.40	0.57	0.03	0.13	0.27	0.04	0.13	
43.5	0.05	0.20	0.40	0.57	0.03	0.13	0.27	0.04	0.13	
45	0.05	0.20	0.40	0.57	0.03	0.13	0.27	0.04	0.13	
46.5	0.05	0.20	0.40	0.57	0.03	0.13	0.28	0.04	0.13	
48	0.05	0.20	0.40	0.57	0.03	0.13	0.28	0.04	0.13	
49.5	0.05	0.20	0.40	0.58	0.03	0.13	0.28	0.04	0.13	
51	0.05	0.20	0.40	0.58	0.03	0.13	0.28	0.04	0.13	
52.5	0.05	0.20	0.40	0.58	0.03	0.13	0.28	0.04	0.13	
54	0.05	0.20	0.40	0.58	0.03	0.13	0.28	0.04	0.13	
55.5	0.05	0.20	0.40	0.58	0.03	0.13	0.28	0.04	0.13	
57	0.05	0.20	0.40	0.58	0.03	0.13	0.28	0.04	0.13	
58.5	0.05	0.20	0.40	0.58	0.03	0.13	0.28	0.04	0.13	
60	0.05	0.20	0.40	0.58	0.03	0.14	0.28	0.04	0.13	
61.5	0.05	0.20	0.40	0.58	0.03	0.14	0.28	0.04	0.13	
63	0.05	0.20	0.40	0.58	0.03	0.14	0.28	0.04	0.13	
64.5	0.05	0.20	0.40	0.58	0.03	0.14	0.28	0.04	0.13	
66	0.05	0.20	0.40	0.58	0.03	0.14	0.28	0.04	0.13	
67.5	0.05	0.20	0.40	0.58	0.03	0.14	0.28	0.04	0.13	
69	0.05	0.20	0.40	0.58	0.03	0.14	0.28	0.04	0.13	
70.5	0.05	0.20	0.40	0.58	0.03	0.14	0.28	0.04	0.13	
72	0.05	0.20	0.40	0.58	0.03	0.14	0.28	0.04	0.13	
73.5	0.05	0.20	0.40	0.58	0.03	0.14	0.28	0.04	0.13	
75	0.05	0.20	0.40	0.58	0.03	0.14	0.28	0.04	0.13	
76.5	0.05	0.20	0.40	0.58	0.03	0.14	0.28	0.04	0.13	
78	0.05	0.20	0.40	0.58	0.03	0.14	0.28	0.04	0.13	
79.5	0.05	0.20	0.40	0.58	0.03	0.14	0.28	0.04	0.13	
81	0.05	0.20	0.40	0.58	0.03	0.14	0.28	0.04	0.13	

Note:

1. Tabulated values assume buckling in the width direction.
2. Tabulated values conservatively assume column buckling failure. For relatively short, highly-loaded columns, a more rigorous analysis using the NDS provisions will increase the Design Load Ratio, R_s.

Table 3C. Solid Sawn Timbers

Rating	1-HOUR				1.5-HOUR			2-HOUR		
	Col. Width	5.5	7.5	9.5	11.5	7.5	9.5	11.5	9.5	11.5
Col. Depth	Design Load Ratio, R _s									
5.5	0.06									
7.5	0.06	0.22			0.05					
9.5	0.07	0.23	0.39		0.05	0.16		0.05		
11.5	0.07	0.24	0.41	0.56	0.06	0.17	0.29	0.05	0.13	
13.5	0.07	0.25	0.42	0.57	0.06	0.18	0.30	0.06	0.14	
15.5	0.07	0.25	0.43	0.58	0.06	0.18	0.31	0.06	0.15	
17.5	0.08	0.26	0.44	0.59	0.06	0.18	0.31	0.06	0.15	
19.5	0.08	0.26	0.44	0.60	0.07	0.19	0.32	0.06	0.16	
21.5	0.08	0.26	0.45	0.60	0.07	0.19	0.32	0.06	0.16	
23.5	0.08	0.26	0.45	0.61	0.07	0.19	0.33	0.07	0.16	

Design Load Ratios for Compression Members Exposed on Three Sides
 (Structural Calculations at Standard Reference Conditions: C_M=1.0, C_t=1.0, C_i=1.0)
 (Protected Surface in Width Direction)

Table 4A. Southern Pine Glued Laminated Timbers

Rating	1-HOUR				1.5-HOUR			2-HOUR		
	Col. Width	5	6.75	8.5	10.5	6.75	8.5	10.5	8.5	10.5
Col. Depth	Design Load Ratio, R _s									
5.5	0.18									
6.875	0.25	0.38			0.14					
8.25	0.30	0.45	0.56		0.20	0.28			0.12	
9.625	0.33	0.50	0.62	0.72	0.24	0.34	0.43	0.17	0.24	
11	0.36	0.54	0.67	0.78	0.28	0.39	0.49	0.21	0.29	
12.375	0.38	0.57	0.70	0.82	0.30	0.42	0.53	0.25	0.34	
13.75	0.39	0.59	0.73	0.85	0.32	0.45	0.57	0.27	0.37	
15.125	0.41	0.61	0.76	0.88	0.34	0.48	0.60	0.29	0.40	
16.5	0.42	0.63	0.78	0.90	0.35	0.50	0.62	0.31	0.43	
17.875	0.42	0.64	0.79	0.92	0.36	0.51	0.65	0.32	0.45	
19.25	0.43	0.65	0.81	0.94	0.37	0.53	0.66	0.34	0.47	
20.625	0.44	0.66	0.82	0.95	0.38	0.54	0.68	0.35	0.48	
22	0.45	0.67	0.83	0.97	0.39	0.55	0.69	0.36	0.49	
23.375	0.45	0.68	0.84	0.98	0.40	0.56	0.70	0.37	0.51	
24.75	0.45	0.68	0.85	0.99	0.40	0.57	0.72	0.37	0.52	
26.125	0.46	0.69	0.86	1.00	0.41	0.58	0.73	0.38	0.53	
27.5	0.46	0.70	0.86	1.00	0.41	0.58	0.73	0.39	0.53	
28.875	0.47	0.70	0.87	1.00	0.42	0.59	0.74	0.39	0.54	
30.25	0.47	0.71	0.88	1.00	0.42	0.59	0.75	0.40	0.55	
31.625	0.47	0.71	0.88	1.00	0.43	0.60	0.75	0.40	0.55	
33	0.47	0.71	0.89	1.00	0.43	0.60	0.76	0.41	0.56	
34.375	0.48	0.72	0.89	1.00	0.43	0.61	0.77	0.41	0.57	
35.75	0.48	0.72	0.89	1.00	0.43	0.61	0.77	0.41	0.57	
37.125		0.72	0.90	1.00	0.44	0.62	0.78	0.42	0.57	
38.5		0.73	0.90	1.00	0.44	0.62	0.78	0.42	0.58	
39.875		0.73	0.90	1.00	0.44	0.62	0.78	0.42	0.58	
41.25		0.73	0.91	1.00	0.44	0.63	0.79	0.43	0.59	
42.625		0.73	0.91	1.00	0.45	0.63	0.79	0.43	0.59	
44		0.74	0.91	1.00	0.45	0.63	0.79	0.43	0.59	
45.375		0.74	0.92	1.00	0.45	0.63	0.80	0.43	0.60	
46.75		0.74	0.92	1.00	0.45	0.64	0.80	0.43	0.60	
48.125		0.74	0.92	1.00	0.45	0.64	0.80	0.44	0.60	
49.5			0.92	1.00		0.64	0.81	0.44	0.60	
50.875			0.92	1.00		0.64	0.81	0.44	0.61	
52.25			0.93	1.00		0.64	0.81	0.44	0.61	
53.625			0.93	1.00		0.65	0.81	0.44	0.61	
55			0.93	1.00		0.65	0.82	0.44	0.61	
56.375			0.93	1.00		0.65	0.82	0.45	0.62	
57.75			0.93	1.00		0.65	0.82	0.45	0.62	
59.125			0.93	1.00		0.65	0.82	0.45	0.62	
60.5			0.94	1.00		0.65	0.82	0.45	0.62	
61.875			0.94	1.00		0.66	0.82	0.45	0.62	
63.25			0.94	1.00		0.66	0.83	0.45	0.62	
64.625				1.00			0.83	0.62		
66				1.00			0.83	0.63		
67.375				1.00			0.83	0.63		
68.75				1.00			0.83	0.63		
70.125				1.00			0.83	0.63		
71.5				1.00			0.83	0.63		
72.875				1.00			0.84	0.63		
74.25				1.00			0.84	0.63		
75.625				1.00			0.84	0.63		
77				1.00			0.84	0.64		

Table 4B. Western Species Glued Laminated Timbers

Rating	1-HOUR				1.5-HOUR			2-HOUR		
	Col. Width	5.125	6.75	8.75	10.75	6.75	8.5	10.5	8.75	10.75
Col. Depth	Design Load Ratio, R _s									
6	0.22									
7.5	0.29	0.42			0.17					
9	0.33	0.48	0.61		0.22	0.32			0.16	
10.5	0.36	0.53	0.67	0.77	0.26	0.37	0.47	0.21	0.28	
12	0.39	0.56	0.71	0.82	0.29	0.42	0.52	0.25	0.34	
13.5	0.41	0.59	0.75	0.86	0.32	0.45	0.56	0.28	0.38	
15	0.42	0.61	0.77	0.89	0.34	0.48	0.60	0.31	0.41	
16.5	0.43	0.63	0.80	0.92	0.35	0.50	0.62	0.33	0.44	
18	0.44	0.64	0.81	0.94	0.37	0.51	0.65	0.34	0.46	
19.5	0.45	0.65	0.83	0.96	0.38	0.53	0.67	0.36	0.48	
21	0.46	0.66	0.84	0.97	0.39	0.54	0.68	0.37	0.50	
22.5	0.47	0.67	0.85	0.98	0.39	0.55	0.70	0.38	0.51	
24	0.47	0.68	0.86	1.00	0.40	0.56	0.71	0.39	0.53	
25.5	0.48	0.69	0.87	1.00	0.41	0.57	0.72	0.40	0.54	
27	0.48	0.69	0.88	1.00	0.41	0.58	0.73	0.40	0.55	
28.5	0.48	0.70	0.89	1.00	0.42	0.59	0.74	0.41	0.56	
30	0.49	0.70	0.90	1.00	0.42	0.59	0.75	0.42	0.56	
31.5	0.49	0.71	0.90	1.00	0.43	0.60	0.75	0.42	0.57	
33	0.49	0.71	0.91	1.00	0.43	0.60	0.76	0.43	0.58	
34.5	0.50	0.72	0.91	1.00	0.43	0.61	0.77	0.43	0.58	
36	0.50	0.72	0.92	1.00	0.44	0.61	0.77	0.44	0.59	
37.5		0.72	0.92	1.00	0.44	0.62	0.78	0.44	0.59	
39		0.73	0.92	1.00	0.44	0.62	0.78	0.44	0.60	
40.5		0.73	0.93	1.00	0.44	0.62	0.79	0.45	0.60	
42		0.73	0.93	1.00	0.45	0.63	0.79	0.45	0.61	
43.5		0.73	0.93	1.00	0.45	0.63	0.79	0.45	0.61	
45		0.74	0.94	1.00	0.45	0.63	0.80	0.45	0.61	
46.5		0.74	0.94	1.00	0.45	0.64	0.80	0.46	0.62	
48		0.74	0.94	1.00	0.45	0.64	0.80	0.46	0.62	
49.5			0.94	1.00	0.45	0.64	0.81	0.46	0.62	
51			0.95	1.00	0.46	0.64	0.81	0.46	0.63	
52.5			0.95	1.00	0.46	0.64	0.81	0.46	0.63	
54			0.95	1.00		0.65	0.81	0.47	0.63	
55.5			0.95	1.00		0.65	0.82	0.47	0.63	
57			0.95	1.00		0.65	0.82	0.47	0.63	
58.5			0.95	1.00		0.65	0.82	0.47	0.64	
60			0.96	1.00		0.65	0.82	0.47	0.64	
61.5			0.96	1.00		0.65	0.82	0.47	0.64	
63			0.96	1.00		0.66	0.83	0.48	0.64	
64.5				1.00		0.66	0.83	0.64		
66				1.00		0.66	0.83	0.65		
67.5				1.00		0.66	0.83	0.65		
69				1.00		0.66	0.83	0.65		
70.5				1.00			0.83	0.65		
72				1.00			0.83	0.65		
73.5				1.00			0.84	0.65		
75				1.00			0.84	0.65		
76.5				1.00			0.84	0.65		
78				1.00			0.84	0.66		
79.5				1.00			0.84	0.66		
81				1.00			0.84	0.66		

Note:

1. Tabulated values assume buckling in the width direction.
2. Tabulated values conservatively assume column buckling failure. For relatively short, highly-loaded columns, a more rigorous analysis using the NDS provisions will increase the Design Load Ratio, R_s.

Table 4C. Solid Sawn Timbers

Rating	1-HOUR				1.5-HOUR			2-HOUR		
	Col. Width	5.5	7.5	9.5	11.5	7.5	9.5	11.5	9.5	11.5
Col. Depth	Design Load Ratio, R _s									
5.5	0.21									
7.5	0.32	0.46			0.20					
9.5	0.38	0.55	0.67		0.28	0.38		0.20		
11.5	0.42	0.61	0.74	0.84	0.34	0.46	0.55	0.27	0.35	
13.5	0.45	0.65	0.79	0.89	0.38	0.51	0.61	0.32	0.41	
15.5	0.47	0.68	0.83	0.94	0.41	0.55	0.66	0.36	0.46	
17.5	0.49	0.71	0.86	0.97	0.43	0.58	0.69	0.38	0.49	
19.5	0.50	0.73	0.88	0.99	0.45	0.60	0.72	0.41	0.52	
21.5	0.51	0.74	0.90	1.00	0.46	0.62	0.75	0.43	0.55	
23.5	0.52	0.75	0.92	1.00	0.47	0.64	0.77	0.44	0.57	

Design Load Ratios for Compression Members Exposed on Four Sides
(Structural Calculations at Standard Reference Conditions: C_M=1.0, C_t=1.0, C_i=1.0)

Table 5A. Southern Pine Glued Laminated Timbers

Rating	1-HOUR				1.5-HOUR			2-HOUR	
Col. Width	5	6.75	8.5	10.5	6.75	8.5	10.5	8.5	10.5
Col. Depth	Design Load Ratio, R _s								
5.5	0.02								
6.875	0.02 0.10				0.01			0.01	
8.25	0.03 0.12 0.22				0.01 0.06			0.01	
9.625	0.03 0.13 0.24 0.36				0.02 0.07 0.14			0.01 0.04	
11	0.03 0.14 0.26 0.39				0.02 0.08 0.16			0.01 0.05	
12.375	0.03 0.15 0.28 0.41				0.02 0.08 0.17			0.02 0.06	
13.75	0.03 0.15 0.29 0.43				0.02 0.09 0.18			0.02 0.07	
15.125	0.03 0.16 0.30 0.44				0.02 0.09 0.19			0.02 0.07	
16.5	0.03 0.16 0.30 0.45				0.02 0.10 0.20			0.02 0.08	
17.875	0.04 0.16 0.31 0.46				0.03 0.10 0.21			0.02 0.08	
19.25	0.04 0.17 0.32 0.47				0.03 0.10 0.22			0.02 0.09	
20.625	0.04 0.17 0.32 0.48				0.03 0.11 0.22			0.02 0.09	
22	0.04 0.17 0.33 0.48				0.03 0.11 0.22			0.02 0.09	
23.375	0.04 0.17 0.33 0.49				0.03 0.11 0.23			0.02 0.09	
24.75	0.04 0.18 0.33 0.49				0.03 0.11 0.23			0.03 0.10	
26.125	0.04 0.18 0.34 0.50				0.03 0.11 0.24			0.03 0.10	
27.5	0.04 0.18 0.34 0.50				0.03 0.12 0.24			0.03 0.10	
28.875	0.04 0.18 0.34 0.50				0.03 0.12 0.24			0.03 0.10	
30.25	0.04 0.18 0.34 0.51				0.03 0.12 0.24			0.03 0.10	
31.625	0.04 0.18 0.34 0.51				0.03 0.12 0.24			0.03 0.10	
33	0.04 0.18 0.35 0.51				0.03 0.12 0.25			0.03 0.10	
34.375	0.04 0.18 0.35 0.52				0.03 0.12 0.25			0.03 0.10	
35.75	0.04 0.19 0.35 0.52				0.03 0.12 0.25			0.03 0.11	
37.125	0.19 0.35 0.52				0.03 0.12 0.25			0.03 0.11	
38.5	0.19 0.35 0.52				0.03 0.12 0.25			0.03 0.11	
39.875	0.19 0.35 0.52				0.03 0.12 0.25			0.03 0.11	
41.25	0.19 0.35 0.53				0.03 0.12 0.26			0.03 0.11	
42.625	0.19 0.36 0.53				0.03 0.12 0.26			0.03 0.11	
44	0.19 0.36 0.53				0.03 0.12 0.26			0.03 0.11	
45.375	0.19 0.36 0.53				0.03 0.13 0.26			0.03 0.11	
46.75	0.19 0.36 0.53				0.03 0.13 0.26			0.03 0.11	
48.125	0.19 0.36 0.53				0.03 0.13 0.26			0.03 0.11	
49.5	0.36 0.53				0.13 0.26			0.03 0.11	
50.875	0.36 0.54				0.13 0.26			0.03 0.11	
52.25	0.36 0.54				0.13 0.26			0.03 0.11	
53.625	0.36 0.54				0.13 0.26			0.03 0.11	
55	0.36 0.54				0.13 0.26			0.03 0.11	
56.375	0.36 0.54				0.13 0.27			0.03 0.11	
57.75	0.36 0.54				0.13 0.27			0.03 0.11	
59.125	0.37 0.54				0.13 0.27			0.03 0.11	
60.5	0.37 0.54				0.13 0.27			0.03 0.11	
61.875	0.37 0.54				0.13 0.27			0.03 0.11	
63.25	0.37 0.54				0.13 0.27			0.03 0.11	
64.625	0.54				0.27			0.12	
66	0.54				0.27			0.12	
67.375	0.55				0.27			0.12	
68.75	0.55				0.27			0.12	
70.125	0.55				0.27			0.12	
71.5	0.55				0.27			0.12	
72.875	0.55				0.27			0.12	
74.25	0.55				0.27			0.12	
75.625	0.55				0.27			0.12	
77	0.55				0.27			0.12	

Table 5B. Western Species Glued Laminated Timbers

Rating	1-HOUR				1.5-HOUR			2-HOUR	
Col. Width	5.125	6.75	8.75	10.75	6.75	8.5	10.5	8.75	10.75
Col. Depth	Design Load Ratio, R _s								
6	0.02								
7.5	0.03 0.11				0.01			0.01	
9	0.03 0.12 0.25				0.02 0.06			0.01	
10.5	0.04 0.14 0.27 0.39				0.02 0.07 0.15			0.02 0.06	
12	0.04 0.14 0.29 0.42				0.02 0.08 0.17			0.02 0.07	
13.5	0.04 0.15 0.30 0.44				0.02 0.09 0.18			0.02 0.08	
15	0.04 0.16 0.31 0.45				0.02 0.09 0.19			0.03 0.08	
16.5	0.04 0.16 0.32 0.47				0.02 0.10 0.20			0.03 0.09	
18	0.04 0.17 0.33 0.48				0.03 0.10 0.21			0.03 0.09	
19.5	0.04 0.17 0.34 0.49				0.03 0.10 0.22			0.03 0.10	
21	0.04 0.17 0.34 0.49				0.03 0.11 0.22			0.03 0.10	
22.5	0.04 0.17 0.35 0.50				0.03 0.11 0.23			0.03 0.10	
24	0.05 0.18 0.35 0.51				0.03 0.11 0.23			0.03 0.10	
25.5	0.05 0.18 0.36 0.51				0.03 0.11 0.23			0.03 0.11	
27	0.05 0.18 0.36 0.52				0.03 0.11 0.24			0.03 0.11	
28.5	0.05 0.18 0.36 0.52				0.03 0.12 0.24			0.03 0.11	
30	0.05 0.18 0.36 0.53				0.03 0.12 0.24			0.03 0.11	
31.5	0.05 0.18 0.37 0.53				0.03 0.12 0.24			0.03 0.11	
33	0.05 0.18 0.37 0.53				0.03 0.12 0.25			0.03 0.11	
34.5	0.05 0.18 0.37 0.53				0.03 0.12 0.25			0.04 0.12	
36	0.05 0.19 0.37 0.54				0.03 0.12 0.25			0.04 0.12	
37.5	0.19 0.37 0.54				0.03 0.12 0.25			0.04 0.12	
39	0.19 0.38 0.54				0.03 0.12 0.25			0.04 0.12	
40.5	0.19 0.38 0.54				0.03 0.12 0.25			0.04 0.12	
42	0.19 0.38 0.55				0.03 0.12 0.26			0.04 0.12	
43.5	0.19 0.38 0.55				0.03 0.12 0.26			0.04 0.12	
45	0.19 0.38 0.55				0.03 0.13 0.26			0.04 0.12	
46.5	0.19 0.38 0.55				0.03 0.13 0.26			0.04 0.12	
48	0.19 0.38 0.55				0.03 0.13 0.26			0.04 0.12	
49.5	0.38 0.55				0.03 0.13 0.26			0.04 0.12	
51	0.38 0.56				0.03 0.13 0.26			0.04 0.12	
52.5	0.39 0.56				0.03 0.13 0.26			0.04 0.12	
54	0.39 0.56				0.13 0.26			0.04 0.13	
55.5	0.39 0.56				0.13 0.26			0.04 0.13	
57	0.39 0.56				0.13 0.27			0.04 0.13	
58.5	0.39 0.56				0.13 0.27			0.04 0.13	
60	0.39 0.56				0.13 0.27			0.04 0.13	
61.5	0.39 0.56				0.13 0.27			0.04 0.13	
63	0.39 0.56				0.13 0.27			0.04 0.13	
64.5	0.56				0.13 0.27			0.13	
66	0.56				0.13 0.27			0.13	
67.5	0.57				0.13 0.27			0.13	
69	0.57				0.13 0.27			0.13	
70.5	0.57				0.27			0.13	
72	0.57				0.27			0.13	
73.5	0.57				0.27			0.13	
75	0.57				0.27			0.13	
76.5	0.57				0.27			0.13	
78	0.57				0.27			0.13	
79.5	0.57				0.27			0.13	
81	0.57				0.27			0.13	

Note: 1. Tabulated values assume buckling in the width direction.
2. Tabulated values conservatively assume column buckling failure. For relatively short, highly-loaded columns, a more rigorous analysis using the NDS provisions will increase the Design Load Ratio, R_s.

Table 5C. Solid Sawn Timbers

Rating	1-HOUR			1.5-HOUR			2-HOUR		
Col. Width	5.5	7.5	9.5	11.5	7.5	9.5	11.5	9.5	11.5
Col. Depth	Design Load Ratio, R _s								
5.5	0.03								
7.5	0.04 0.15			0.02			0.03		
9.5	0.05 0.18 0.30			0.04 0.10			0.03		
11.5	0.06 0.20 0.33 0.45			0.04 0.12 0.21			0.03 0.08		
13.5	0.06 0.21 0.36 0.48			0.05 0.14 0.23			0.04 0.10		
15.5	0.06 0.22 0.37 0.51			0.05 0.15 0.25			0.04 0.11		
17.5	0.07 0.23 0.39 0.52			0.05 0.15 0.26			0.05 0.12		
19.5	0.07 0.23 0.40 0.54			0.06 0.16 0.27			0.05 0.13		
21.5	0.07 0.24 0.40 0.55			0.06 0.16 0.28			0.05 0.13		
23.5	0.07 0.24 0.41 0.56			0.06 0.17 0.29			0.06 0.14		

Design Load Ratios for Tension Members Exposed on Three Sides
 (Structural Calculations at Standard Reference Conditions: C_D=1.0, C_M=1.0, C_t=1.0, C_i=1.0)
 (Protected Surface in Depth Direction)

Table 6A. Southern Pine Glued Laminated Timbers

Rating	1-HOUR				1.5-HOUR			2-HOUR	
	5	6.75	8.5	10.5	6.75	8.5	10.5	8.5	10.5
Beam Width	Design Load Ratio, R _s								
Beam Depth	Design Load Ratio, R _s								
5.5	0.54	0.89	1.00	1.00	0.40	0.64	0.81	0.31	0.48
6.875	0.59	0.98	1.00	1.00	0.47	0.75	0.95	0.39	0.61
8.25	0.62	1.00	1.00	1.00	0.51	0.82	1.00	0.45	0.70
9.625	0.65	1.00	1.00	1.00	0.54	0.87	1.00	0.49	0.76
11	0.67	1.00	1.00	1.00	0.57	0.91	1.00	0.52	0.81
12.375	0.68	1.00	1.00	1.00	0.59	0.93	1.00	0.54	0.84
13.75	0.69	1.00	1.00	1.00	0.60	0.96	1.00	0.56	0.87
15.125	0.70	1.00	1.00	1.00	0.61	0.98	1.00	0.58	0.90
16.5	0.71	1.00	1.00	1.00	0.62	0.99	1.00	0.59	0.92
17.875	0.72	1.00	1.00	1.00	0.63	1.00	1.00	0.60	0.93
19.25	0.72	1.00	1.00	1.00	0.64	1.00	1.00	0.61	0.95
20.625	0.73	1.00	1.00	1.00	0.65	1.00	1.00	0.62	0.96
22	0.73	1.00	1.00	1.00	0.65	1.00	1.00	0.62	0.97
23.375	0.74	1.00	1.00	1.00	0.66	1.00	1.00	0.63	0.98
24.75	0.74	1.00	1.00	1.00	0.66	1.00	1.00	0.64	0.99
26.125	0.74	1.00	1.00	1.00	0.67	1.00	1.00	0.64	1.00
27.5	0.75	1.00	1.00	1.00	0.67	1.00	1.00	0.65	1.00
28.875	0.75	1.00	1.00	1.00	0.67	1.00	1.00	0.65	1.00
30.25	0.75	1.00	1.00	1.00	0.68	1.00	1.00	0.65	1.00
31.625	0.75	1.00	1.00	1.00	0.68	1.00	1.00	0.66	1.00
33	0.75	1.00	1.00	1.00	0.68	1.00	1.00	0.66	1.00
34.375	0.76	1.00	1.00	1.00	0.68	1.00	1.00	0.66	1.00
35.75	0.76	1.00	1.00	1.00	0.68	1.00	1.00	0.66	1.00
37.125	1.00	1.00	1.00	1.00	0.69	1.00	1.00	0.67	1.00
38.5	1.00	1.00	1.00	1.00	0.69	1.00	1.00	0.67	1.00
39.875	1.00	1.00	1.00	1.00	0.69	1.00	1.00	0.67	1.00
41.25	1.00	1.00	1.00	1.00	0.69	1.00	1.00	0.67	1.00
42.625	1.00	1.00	1.00	1.00	0.69	1.00	1.00	0.68	1.00
44	1.00	1.00	1.00	1.00	0.69	1.00	1.00	0.68	1.00
45.375	1.00	1.00	1.00	1.00	0.70	1.00	1.00	0.68	1.00
46.75	1.00	1.00	1.00	1.00	0.70	1.00	1.00	0.68	1.00
48.125	1.00	1.00	1.00	1.00	0.70	1.00	1.00	0.68	1.00
49.5	1.00	1.00	1.00	1.00	1.00	1.00	1.00	0.68	1.00
50.875	1.00	1.00	1.00	1.00	1.00	1.00	1.00	0.68	1.00
52.25	1.00	1.00	1.00	1.00	1.00	1.00	1.00	0.69	1.00
53.625	1.00	1.00	1.00	1.00	1.00	1.00	1.00	0.69	1.00
55	1.00	1.00	1.00	1.00	1.00	1.00	1.00	0.69	1.00
56.375	1.00	1.00	1.00	1.00	1.00	1.00	1.00	0.69	1.00
57.75	1.00	1.00	1.00	1.00	1.00	1.00	1.00	0.69	1.00
59.125	1.00	1.00	1.00	1.00	1.00	1.00	1.00	0.69	1.00
60.5	1.00	1.00	1.00	1.00	1.00	1.00	1.00	0.69	1.00
61.875	1.00	1.00	1.00	1.00	1.00	1.00	1.00	0.69	1.00
63.25	1.00	1.00	1.00	1.00	1.00	1.00	1.00	0.69	1.00
64.625	1.00	1.00	1.00	1.00	1.00	1.00	1.00	1.00	1.00
66	1.00	1.00	1.00	1.00	1.00	1.00	1.00	1.00	1.00
67.375	1.00	1.00	1.00	1.00	1.00	1.00	1.00	1.00	1.00
68.75	1.00	1.00	1.00	1.00	1.00	1.00	1.00	1.00	1.00
70.125	1.00	1.00	1.00	1.00	1.00	1.00	1.00	1.00	1.00
71.5	1.00	1.00	1.00	1.00	1.00	1.00	1.00	1.00	1.00
72.875	1.00	1.00	1.00	1.00	1.00	1.00	1.00	1.00	1.00
74.25	1.00	1.00	1.00	1.00	1.00	1.00	1.00	1.00	1.00
75.625	1.00	1.00	1.00	1.00	1.00	1.00	1.00	1.00	1.00
77	1.00	1.00	1.00	1.00	1.00	1.00	1.00	1.00	1.00

Table 6B. Western Species Glued Laminated Timbers

Rating	1-HOUR				1.5-HOUR			2-HOUR	
	5.13	6.75	8.75	10.8	6.75	8.75	10.8	8.75	10.8
Beam Width	Design Load Ratio, R _s								
Beam Depth	Design Load Ratio, R _s								
6	0.59	0.93	1.00	1.00	0.43	0.71	0.89	0.37	0.55
7.5	0.64	1.00	1.00	1.00	0.49	0.81	1.00	0.46	0.68
9	0.68	1.00	1.00	1.00	0.53	0.88	1.00	0.51	0.76
10.5	0.70	1.00	1.00	1.00	0.56	0.93	1.00	0.55	0.82
12	0.72	1.00	1.00	1.00	0.58	0.97	1.00	0.58	0.86
13.5	0.73	1.00	1.00	1.00	0.60	0.99	1.00	0.60	0.90
15	0.75	1.00	1.00	1.00	0.61	1.00	1.00	0.62	0.93
16.5	0.76	1.00	1.00	1.00	0.62	1.00	1.00	0.64	0.95
18	0.76	1.00	1.00	1.00	0.63	1.00	1.00	0.65	0.97
19.5	0.77	1.00	1.00	1.00	0.64	1.00	1.00	0.66	0.98
21	0.78	1.00	1.00	1.00	0.65	1.00	1.00	0.67	1.00
22.5	0.78	1.00	1.00	1.00	0.65	1.00	1.00	0.68	1.00
24	0.78	1.00	1.00	1.00	0.66	1.00	1.00	0.69	1.00
25.5	0.79	1.00	1.00	1.00	0.66	1.00	1.00	0.69	1.00
27	0.79	1.00	1.00	1.00	0.67	1.00	1.00	0.70	1.00
28.5	0.79	1.00	1.00	1.00	0.67	1.00	1.00	0.70	1.00
30	0.80	1.00	1.00	1.00	0.68	1.00	1.00	0.71	1.00
31.5	0.80	1.00	1.00	1.00	0.68	1.00	1.00	0.71	1.00
33	0.80	1.00	1.00	1.00	0.68	1.00	1.00	0.71	1.00
34.5	0.80	1.00	1.00	1.00	0.68	1.00	1.00	0.72	1.00
36	0.81	1.00	1.00	1.00	0.69	1.00	1.00	0.72	1.00
37.5	1.00	1.00	1.00	1.00	0.69	1.00	1.00	0.72	1.00
39	1.00	1.00	1.00	1.00	0.69	1.00	1.00	0.73	1.00
40.5	1.00	1.00	1.00	1.00	0.69	1.00	1.00	0.73	1.00
42	1.00	1.00	1.00	1.00	0.69	1.00	1.00	0.73	1.00
43.5	1.00	1.00	1.00	1.00	0.69	1.00	1.00	0.73	1.00
45	1.00	1.00	1.00	1.00	0.70	1.00	1.00	0.73	1.00
46.5	1.00	1.00	1.00	1.00	0.70	1.00	1.00	0.74	1.00
48	1.00	1.00	1.00	1.00	0.70	1.00	1.00	0.74	1.00
49.5	1.00	1.00	1.00	1.00	1.00	1.00	1.00	0.74	1.00
51	1.00	1.00	1.00	1.00	1.00	1.00	1.00	0.74	1.00
52.5	1.00	1.00	1.00	1.00	1.00	1.00	1.00	0.74	1.00
54	1.00	1.00	1.00	1.00	1.00	1.00	1.00	0.74	1.00
55.5	1.00	1.00	1.00	1.00	1.00	1.00	1.00	0.74	1.00
57	1.00	1.00	1.00	1.00	1.00	1.00	1.00	0.75	1.00
58.5	1.00	1.00	1.00	1.00	1.00	1.00	1.00	0.75	1.00
60	1.00	1.00	1.00	1.00	1.00	1.00	1.00	0.75	1.00
61.5	1.00	1.00	1.00	1.00	1.00	1.00	1.00	0.75	1.00
63	1.00	1.00	1.00	1.00	1.00	1.00	1.00	0.75	1.00
64.5	1.00	1.00	1.00	1.00	1.00	1.00	1.00	1.00	1.00
66	1.00	1.00	1.00	1.00	1.00	1.00	1.00	1.00	1.00
67.5	1.00	1.00	1.00	1.00	1.00	1.00	1.00	1.00	1.00
69	1.00	1.00	1.00	1.00	1.00	1.00	1.00	1.00	1.00
70.5	1.00	1.00	1.00	1.00	1.00	1.00	1.00	1.00	1.00
72	1.00	1.00	1.00	1.00	1.00	1.00	1.00	1.00	1.00
73.5	1.00	1.00	1.00	1.00	1.00	1.00	1.00	1.00	1.00
75	1.00	1.00	1.00	1.00	1.00	1.00	1.00	1.00	1.00
76.5	1.00	1.00	1.00	1.00	1.00	1.00	1.00	1.00	1.00
78	1.00	1.00	1.00	1.00	1.00	1.00	1.00	1.00	1.00
79.5	1.00	1.00	1.00	1.00	1.00	1.00	1.00	1.00	1.00
81	1.00	1.00	1.00	1.00	1.00	1.00	1.00	1.00	1.00

Table 6C. Solid Sawn Timbers

Rating	1-HOUR				1.5-HOUR			2-HOUR	
	5.5	7.5	9.5	11.5	7.5	9.5	11.5	9.5	11.5
Beam Width	Design Load Ratio, R _s								
Beam Depth	Design Load Ratio, R _s								
5.5	0.66	1.00	1.00	1.00	0.52	0.73	0.88	0.40	0.55
7.5	0.75	1.00	1.00	1.00	0.63	0.90	1.00	0.55	0.74
9.5	0.80	1.00	1.00	1.00	0.70	0.99	1.00	0.64	0.86
11.5	0.83	1.00	1.00	1.00	0.74	1.00	1.00	0.69	0.93
13.5	0.85	1.00	1.00	1.00	0.77	1.00	1.00	0.73	0.98
15.5	0.87	1.00	1.00	1.00	0.79	1.00	1.00	0.76	1.00
17.5	0.88	1.00	1.00	1.00	0.81	1.00	1.00	0.78	1.00
19.5	0.89	1.00	1.00	1.00	0.83	1.00	1.00	0.80	1.00
21.5	0.90	1.00	1.00	1.00	0.84	1.00	1.00	0.81	1.00
23.5	0.91	1.00	1.00	1.00	0.85	1.00	1.00	0.82	1.00

Design Load Ratios for Tension Members Exposed on Three Sides
 (Structural Calculations at Standard Reference Conditions: C_D=1.0, C_M=1.0, C_t=1.0, C_i=1.0)
 (Protected Surface in Width Direction)

Table 7A. Southern Pine Glued Laminated Timbers

Rating	1-HOUR				1.5-HOUR			2-HOUR		
	Beam Width	5	6.75	8.5	10.5	6.75	8.5	10.5	8.5	10.5
Beam Depth	Design Load Ratio, R _s									
5.5	0.63	0.72	0.78	0.82	0.16	0.18	0.20			
6.875	0.87	1.00	1.00	1.00	0.49	0.55	0.59	0.14	0.16	
8.25	1.00	1.00	1.00	1.00	0.71	0.79	0.85	0.42	0.46	
9.625	1.00	1.00	1.00	1.00	0.86	0.97	1.00	0.61	0.68	
11	1.00	1.00	1.00	1.00	0.98	1.00	1.00	0.76	0.85	
12.375	1.00	1.00	1.00	1.00	1.00	1.00	1.00	0.87	0.97	
13.75	1.00	1.00	1.00	1.00	1.00	1.00	1.00	0.97	1.00	
15.125	1.00	1.00	1.00	1.00	1.00	1.00	1.00	1.00	1.00	
16.5	1.00	1.00	1.00	1.00	1.00	1.00	1.00	1.00	1.00	
17.875	1.00	1.00	1.00	1.00	1.00	1.00	1.00	1.00	1.00	
19.25	1.00	1.00	1.00	1.00	1.00	1.00	1.00	1.00	1.00	
20.625	1.00	1.00	1.00	1.00	1.00	1.00	1.00	1.00	1.00	
22	1.00	1.00	1.00	1.00	1.00	1.00	1.00	1.00	1.00	
23.375	1.00	1.00	1.00	1.00	1.00	1.00	1.00	1.00	1.00	
24.75	1.00	1.00	1.00	1.00	1.00	1.00	1.00	1.00	1.00	
26.125	1.00	1.00	1.00	1.00	1.00	1.00	1.00	1.00	1.00	
27.5	1.00	1.00	1.00	1.00	1.00	1.00	1.00	1.00	1.00	
28.875	1.00	1.00	1.00	1.00	1.00	1.00	1.00	1.00	1.00	
30.25	1.00	1.00	1.00	1.00	1.00	1.00	1.00	1.00	1.00	
31.625	1.00	1.00	1.00	1.00	1.00	1.00	1.00	1.00	1.00	
33	1.00	1.00	1.00	1.00	1.00	1.00	1.00	1.00	1.00	
34.375	1.00	1.00	1.00	1.00	1.00	1.00	1.00	1.00	1.00	
35.75	1.00	1.00	1.00	1.00	1.00	1.00	1.00	1.00	1.00	
37.125	1.00	1.00	1.00	1.00	1.00	1.00	1.00	1.00	1.00	
38.5	1.00	1.00	1.00	1.00	1.00	1.00	1.00	1.00	1.00	
39.875	1.00	1.00	1.00	1.00	1.00	1.00	1.00	1.00	1.00	
41.25	1.00	1.00	1.00	1.00	1.00	1.00	1.00	1.00	1.00	
42.625	1.00	1.00	1.00	1.00	1.00	1.00	1.00	1.00	1.00	
44	1.00	1.00	1.00	1.00	1.00	1.00	1.00	1.00	1.00	
45.375	1.00	1.00	1.00	1.00	1.00	1.00	1.00	1.00	1.00	
46.75	1.00	1.00	1.00	1.00	1.00	1.00	1.00	1.00	1.00	
48.125	1.00	1.00	1.00	1.00	1.00	1.00	1.00	1.00	1.00	
49.5	1.00	1.00	1.00	1.00	1.00	1.00	1.00	1.00	1.00	
50.875	1.00	1.00	1.00	1.00	1.00	1.00	1.00	1.00	1.00	
52.25	1.00	1.00	1.00	1.00	1.00	1.00	1.00	1.00	1.00	
53.625	1.00	1.00	1.00	1.00	1.00	1.00	1.00	1.00	1.00	
55	1.00	1.00	1.00	1.00	1.00	1.00	1.00	1.00	1.00	
56.375	1.00	1.00	1.00	1.00	1.00	1.00	1.00	1.00	1.00	
57.75	1.00	1.00	1.00	1.00	1.00	1.00	1.00	1.00	1.00	
59.125	1.00	1.00	1.00	1.00	1.00	1.00	1.00	1.00	1.00	
60.5	1.00	1.00	1.00	1.00	1.00	1.00	1.00	1.00	1.00	
61.875	1.00	1.00	1.00	1.00	1.00	1.00	1.00	1.00	1.00	
63.25	1.00	1.00	1.00	1.00	1.00	1.00	1.00	1.00	1.00	
64.625	1.00	1.00	1.00	1.00	1.00	1.00	1.00	1.00	1.00	
66	1.00	1.00	1.00	1.00	1.00	1.00	1.00	1.00	1.00	
67.375	1.00	1.00	1.00	1.00	1.00	1.00	1.00	1.00	1.00	
68.75	1.00	1.00	1.00	1.00	1.00	1.00	1.00	1.00	1.00	
70.125	1.00	1.00	1.00	1.00	1.00	1.00	1.00	1.00	1.00	
71.5	1.00	1.00	1.00	1.00	1.00	1.00	1.00	1.00	1.00	
72.875	1.00	1.00	1.00	1.00	1.00	1.00	1.00	1.00	1.00	
74.25	1.00	1.00	1.00	1.00	1.00	1.00	1.00	1.00	1.00	
75.625	1.00	1.00	1.00	1.00	1.00	1.00	1.00	1.00	1.00	
77	1.00	1.00	1.00	1.00	1.00	1.00	1.00	1.00	1.00	

Table 7B. Western Species Glued Laminated Timbers

Rating	1-HOUR				1.5-HOUR			2-HOUR		
	Beam Width	5.13	6.75	8.75	10.8	6.75	8.75	10.8	8.75	10.8
Beam Depth	Design Load Ratio, R _s									
6	0.74	0.84	0.91	0.95	0.30	0.34	0.36			
7.5	0.96	1.00	1.00	1.00	0.60	0.68	0.73	0.29	0.32	
9	1.00	1.00	1.00	1.00	0.80	0.90	0.97	0.54	0.60	
10.5	1.00	1.00	1.00	1.00	0.94	1.00	1.00	0.72	0.80	
12	1.00	1.00	1.00	1.00	1.00	1.00	1.00	0.86	0.95	
13.5	1.00	1.00	1.00	1.00	1.00	1.00	1.00	0.97	1.00	
15	1.00	1.00	1.00	1.00	1.00	1.00	1.00	1.00	1.00	
16.5	1.00	1.00	1.00	1.00	1.00	1.00	1.00	1.00	1.00	
18	1.00	1.00	1.00	1.00	1.00	1.00	1.00	1.00	1.00	
19.5	1.00	1.00	1.00	1.00	1.00	1.00	1.00	1.00	1.00	
21	1.00	1.00	1.00	1.00	1.00	1.00	1.00	1.00	1.00	
22.5	1.00	1.00	1.00	1.00	1.00	1.00	1.00	1.00	1.00	
24	1.00	1.00	1.00	1.00	1.00	1.00	1.00	1.00	1.00	
25.5	1.00	1.00	1.00	1.00	1.00	1.00	1.00	1.00	1.00	
27	1.00	1.00	1.00	1.00	1.00	1.00	1.00	1.00	1.00	
28.5	1.00	1.00	1.00	1.00	1.00	1.00	1.00	1.00	1.00	
30	1.00	1.00	1.00	1.00	1.00	1.00	1.00	1.00	1.00	
31.5	1.00	1.00	1.00	1.00	1.00	1.00	1.00	1.00	1.00	
33	1.00	1.00	1.00	1.00	1.00	1.00	1.00	1.00	1.00	
34.5	1.00	1.00	1.00	1.00	1.00	1.00	1.00	1.00	1.00	
36	1.00	1.00	1.00	1.00	1.00	1.00	1.00	1.00	1.00	
37.5	1.00	1.00	1.00	1.00	1.00	1.00	1.00	1.00	1.00	
39	1.00	1.00	1.00	1.00	1.00	1.00	1.00	1.00	1.00	
40.5	1.00	1.00	1.00	1.00	1.00	1.00	1.00	1.00	1.00	
42	1.00	1.00	1.00	1.00	1.00	1.00	1.00	1.00	1.00	
43.5	1.00	1.00	1.00	1.00	1.00	1.00	1.00	1.00	1.00	
45	1.00	1.00	1.00	1.00	1.00	1.00	1.00	1.00	1.00	
46.5	1.00	1.00	1.00	1.00	1.00	1.00	1.00	1.00	1.00	
48	1.00	1.00	1.00	1.00	1.00	1.00	1.00	1.00	1.00	
49.5	1.00	1.00	1.00	1.00	1.00	1.00	1.00	1.00	1.00	
51	1.00	1.00	1.00	1.00	1.00	1.00	1.00	1.00	1.00	
52.5	1.00	1.00	1.00	1.00	1.00	1.00	1.00	1.00	1.00	
54	1.00	1.00	1.00	1.00	1.00	1.00	1.00	1.00	1.00	
55.5	1.00	1.00	1.00	1.00	1.00	1.00	1.00	1.00	1.00	
57	1.00	1.00	1.00	1.00	1.00	1.00	1.00	1.00	1.00	
58.5	1.00	1.00	1.00	1.00	1.00	1.00	1.00	1.00	1.00	
60	1.00	1.00	1.00	1.00	1.00	1.00	1.00	1.00	1.00	
61.5	1.00	1.00	1.00	1.00	1.00	1.00	1.00	1.00	1.00	
63	1.00	1.00	1.00	1.00	1.00	1.00	1.00	1.00	1.00	
64.5	1.00	1.00	1.00	1.00	1.00	1.00	1.00	1.00	1.00	
66	1.00	1.00	1.00	1.00	1.00	1.00	1.00	1.00	1.00	
67.5	1.00	1.00	1.00	1.00	1.00	1.00	1.00	1.00	1.00	
69	1.00	1.00	1.00	1.00	1.00	1.00	1.00	1.00	1.00	
70.5	1.00	1.00	1.00	1.00	1.00	1.00	1.00	1.00	1.00	
72	1.00	1.00	1.00	1.00	1.00	1.00	1.00	1.00	1.00	
73.5	1.00	1.00	1.00	1.00	1.00	1.00	1.00	1.00	1.00	
75	1.00	1.00	1.00	1.00	1.00	1.00	1.00	1.00	1.00	
76.5	1.00	1.00	1.00	1.00	1.00	1.00	1.00	1.00	1.00	
78	1.00	1.00	1.00	1.00	1.00	1.00	1.00	1.00	1.00	
79.5	1.00	1.00	1.00	1.00	1.00	1.00	1.00	1.00	1.00	
81	1.00	1.00	1.00	1.00	1.00	1.00	1.00	1.00	1.00	

Table 7C. Solid Sawn Timbers

Rating	1-HOUR				1.5-HOUR			2-HOUR		
	Beam Width	5.5	7.5	9.5	11.5	7.5	9.5	11.5	9.5	11.5
Beam Depth	Design Load Ratio, R _s									
5.5	0.66	0.75	0.80	0.83	0.17	0.19	0.20			
7.5	1.00	1.00	1.00	1.00	0.63	0.70	0.74	0.30	0.32	
9.5	1.00	1.00	1.00	1.00	0.90	0.99	1.00	0.64	0.69	
11.5	1.00	1.00	1.00	1.00	1.00	1.00	1.00	0.86	0.93	
13.5	1.00	1.00	1.00	1.00	1.00	1.00	1.00	1.00	1.00	
15.5	1.00	1.00	1.00	1.00	1.00	1.00	1.00	1.00	1.00	
17.5	1.00	1.00	1.00	1.00	1.00	1.00	1.00	1.00	1.00	
19.5	1.00	1.00	1.00	1.00	1.00	1.00	1.00	1.00	1.00	
21.5	1.00	1.00	1.00	1.00	1.00	1.00	1.00	1.00	1.00	
23.5	1.00	1.00	1.00	1.00	1.00	1.00	1.00	1.00	1.00	

Design Load Ratios for Tension Members Exposed on Four Sides
(Structural Calculations at Standard Reference Conditions: C_D=1.0, C_M=1.0, C_t=1.0, C_i=1.0)

Table 8A. Southern Pine Glued Laminated Timbers

Rating	1-HOUR				1.5-HOUR			2-HOUR		
	Beam Width	5	6.75	8.5	10.5	6.75	8.5	10.5	8.5	10.5
Beam Depth	Design Load Ratio, R _s									
5.5	0.28	0.46	0.57	0.65	0.07	0.11	0.13			
6.875	0.38	0.63	0.78	0.89	0.20	0.32	0.41	0.06	0.09	
8.25	0.45	0.75	0.93	1.00	0.29	0.46	0.59	0.17	0.26	
9.625	0.50	0.83	1.00	1.00	0.35	0.56	0.72	0.25	0.39	
11	0.54	0.89	1.00	1.00	0.40	0.64	0.81	0.31	0.48	
12.375	0.57	0.94	1.00	1.00	0.44	0.70	0.89	0.36	0.55	
13.75	0.59	0.98	1.00	1.00	0.47	0.75	0.95	0.39	0.61	
15.125	0.61	1.00	1.00	1.00	0.49	0.78	1.00	0.42	0.66	
16.5	0.62	1.00	1.00	1.00	0.51	0.82	1.00	0.45	0.70	
17.875	0.64	1.00	1.00	1.00	0.53	0.84	1.00	0.47	0.73	
19.25	0.65	1.00	1.00	1.00	0.54	0.87	1.00	0.49	0.76	
20.625	0.66	1.00	1.00	1.00	0.56	0.89	1.00	0.51	0.79	
22	0.67	1.00	1.00	1.00	0.57	0.91	1.00	0.52	0.81	
23.375	0.68	1.00	1.00	1.00	0.58	0.92	1.00	0.53	0.83	
24.75	0.68	1.00	1.00	1.00	0.59	0.93	1.00	0.54	0.84	
26.125	0.69	1.00	1.00	1.00	0.60	0.95	1.00	0.55	0.86	
27.5	0.69	1.00	1.00	1.00	0.60	0.96	1.00	0.56	0.87	
28.875	0.70	1.00	1.00	1.00	0.61	0.97	1.00	0.57	0.89	
30.25	0.70	1.00	1.00	1.00	0.61	0.98	1.00	0.58	0.90	
31.625	0.71	1.00	1.00	1.00	0.62	0.99	1.00	0.58	0.91	
33	0.71	1.00	1.00	1.00	0.62	0.99	1.00	0.59	0.92	
34.375	0.71	1.00	1.00	1.00	0.63	1.00	1.00	0.60	0.92	
35.75	0.72	1.00	1.00	1.00	0.63	1.00	1.00	0.60	0.93	
37.125	1.00	1.00	1.00	1.00	0.64	1.00	1.00	0.61	0.94	
38.5	1.00	1.00	1.00	1.00	0.64	1.00	1.00	0.61	0.95	
39.875	1.00	1.00	1.00	1.00	0.64	1.00	1.00	0.61	0.95	
41.25	1.00	1.00	1.00	1.00	0.65	1.00	1.00	0.62	0.96	
42.625	1.00	1.00	1.00	1.00	0.65	1.00	1.00	0.62	0.97	
44	1.00	1.00	1.00	1.00	0.65	1.00	1.00	0.62	0.97	
45.375	1.00	1.00	1.00	1.00	0.66	1.00	1.00	0.63	0.98	
46.75	1.00	1.00	1.00	1.00	0.66	1.00	1.00	0.63	0.98	
48.125	1.00	1.00	1.00	1.00	0.66	1.00	1.00	0.63	0.98	
49.5	1.00	1.00	1.00	1.00	1.00	1.00	1.00	0.64	0.99	
50.875	1.00	1.00	1.00	1.00	1.00	1.00	1.00	0.64	0.99	
52.25	1.00	1.00	1.00	1.00	1.00	1.00	1.00	0.64	1.00	
53.625	1.00	1.00	1.00	1.00	1.00	1.00	1.00	0.64	1.00	
55	1.00	1.00	1.00	1.00	1.00	1.00	1.00	0.65	1.00	
56.375	1.00	1.00	1.00	1.00	1.00	1.00	1.00	0.65	1.00	
57.75	1.00	1.00	1.00	1.00	1.00	1.00	1.00	0.65	1.00	
59.125	1.00	1.00	1.00	1.00	1.00	1.00	1.00	0.65	1.00	
60.5	1.00	1.00	1.00	1.00	1.00	1.00	1.00	0.65	1.00	
61.875	1.00	1.00	1.00	1.00	1.00	1.00	1.00	0.65	1.00	
63.25	1.00	1.00	1.00	1.00	1.00	1.00	1.00	0.66	1.00	
64.625	1.00	1.00	1.00	1.00	1.00	1.00	1.00	1.00	1.00	
66	1.00	1.00	1.00	1.00	1.00	1.00	1.00	1.00	1.00	
67.375	1.00	1.00	1.00	1.00	1.00	1.00	1.00	1.00	1.00	
68.75	1.00	1.00	1.00	1.00	1.00	1.00	1.00	1.00	1.00	
70.125	1.00	1.00	1.00	1.00	1.00	1.00	1.00	1.00	1.00	
71.5	1.00	1.00	1.00	1.00	1.00	1.00	1.00	1.00	1.00	
72.875	1.00	1.00	1.00	1.00	1.00	1.00	1.00	1.00	1.00	
74.25	1.00	1.00	1.00	1.00	1.00	1.00	1.00	1.00	1.00	
75.625	1.00	1.00	1.00	1.00	1.00	1.00	1.00	1.00	1.00	
77	1.00	1.00	1.00	1.00	1.00	1.00	1.00	1.00	1.00	

Table 8B. Western Species Glued Laminated Timbers

Rating	1-HOUR				1.5-HOUR			2-HOUR		
	Beam Width	5.13	6.75	8.75	10.8	6.75	8.75	10.8	8.75	10.8
Beam Depth	Design Load Ratio, R _s									
6	0.34	0.53	0.67	0.76	0.12	0.20	0.25			
7.5	0.44	0.69	0.87	0.99	0.24	0.41	0.51	0.12	0.18	
9	0.51	0.80	1.00	1.00	0.33	0.54	0.68	0.23	0.35	
10.5	0.56	0.87	1.00	1.00	0.39	0.64	0.80	0.31	0.47	
12	0.59	0.93	1.00	1.00	0.43	0.71	0.89	0.37	0.55	
13.5	0.62	0.98	1.00	1.00	0.46	0.77	0.96	0.42	0.62	
15	0.64	1.00	1.00	1.00	0.49	0.81	1.00	0.46	0.68	
16.5	0.66	1.00	1.00	1.00	0.51	0.85	1.00	0.49	0.72	
18	0.68	1.00	1.00	1.00	0.53	0.88	1.00	0.51	0.76	
19.5	0.69	1.00	1.00	1.00	0.55	0.91	1.00	0.53	0.79	
21	0.70	1.00	1.00	1.00	0.56	0.93	1.00	0.55	0.82	
22.5	0.71	1.00	1.00	1.00	0.57	0.95	1.00	0.57	0.84	
24	0.72	1.00	1.00	1.00	0.58	0.97	1.00	0.58	0.86	
25.5	0.73	1.00	1.00	1.00	0.59	0.98	1.00	0.59	0.88	
27	0.73	1.00	1.00	1.00	0.60	0.99	1.00	0.60	0.90	
28.5	0.74	1.00	1.00	1.00	0.61	1.00	1.00	0.61	0.91	
30	0.75	1.00	1.00	1.00	0.61	1.00	1.00	0.62	0.93	
31.5	0.75	1.00	1.00	1.00	0.62	1.00	1.00	0.63	0.94	
33	0.76	1.00	1.00	1.00	0.62	1.00	1.00	0.64	0.95	
34.5	0.76	1.00	1.00	1.00	0.63	1.00	1.00	0.65	0.96	
36	0.76	1.00	1.00	1.00	0.63	1.00	1.00	0.65	0.97	
37.5	1.00	1.00	1.00	1.00	0.64	1.00	1.00	0.66	0.98	
39	1.00	1.00	1.00	1.00	0.64	1.00	1.00	0.66	0.98	
40.5	1.00	1.00	1.00	1.00	0.65	1.00	1.00	0.67	0.99	
42	1.00	1.00	1.00	1.00	0.65	1.00	1.00	0.67	1.00	
43.5	1.00	1.00	1.00	1.00	0.65	1.00	1.00	0.68	1.00	
45	1.00	1.00	1.00	1.00	0.65	1.00	1.00	0.68	1.00	
46.5	1.00	1.00	1.00	1.00	0.66	1.00	1.00	0.68	1.00	
48	1.00	1.00	1.00	1.00	0.66	1.00	1.00	0.69	1.00	
49.5	1.00	1.00	1.00	1.00	1.00	1.00	1.00	0.69	1.00	
51	1.00	1.00	1.00	1.00	1.00	1.00	1.00	0.69	1.00	
52.5	1.00	1.00	1.00	1.00	1.00	1.00	1.00	0.69	1.00	
54	1.00	1.00	1.00	1.00	1.00	1.00	1.00	0.70	1.00	
55.5	1.00	1.00	1.00	1.00	1.00	1.00	1.00	0.70	1.00	
57	1.00	1.00	1.00	1.00	1.00	1.00	1.00	0.70	1.00	
58.5	1.00	1.00	1.00	1.00	1.00	1.00	1.00	0.70	1.00	
60	1.00	1.00	1.00	1.00	1.00	1.00	1.00	0.71	1.00	
61.5	1.00	1.00	1.00	1.00	1.00	1.00	1.00	0.71	1.00	
63	1.00	1.00	1.00	1.00	1.00	1.00	1.00	0.71	1.00	
64.5	1.00	1.00	1.00	1.00	1.00	1.00	1.00	1.00	1.00	
66	1.00	1.00	1.00	1.00	1.00	1.00	1.00	1.00	1.00	
67.5	1.00	1.00	1.00	1.00	1.00	1.00	1.00	1.00	1.00	
69	1.00	1.00	1.00	1.00	1.00	1.00	1.00	1.00	1.00	
70.5	1.00	1.00	1.00	1.00	1.00	1.00	1.00	1.00	1.00	
72	1.00	1.00	1.00	1.00	1.00	1.00	1.00	1.00	1.00	
73.5	1.00	1.00	1.00	1.00	1.00	1.00	1.00	1.00	1.00	
75	1.00	1.00	1.00	1.00	1.00	1.00	1.00	1.00	1.00	
76.5	1.00	1.00	1.00	1.00	1.00	1.00	1.00	1.00	1.00	
78	1.00	1.00	1.00	1.00	1.00	1.00	1.00	1.00	1.00	
79.5	1.00	1.00	1.00	1.00	1.00	1.00	1.00	1.00	1.00	
81	1.00	1.00	1.00	1.00	1.00	1.00	1.00	1.00	1.00	

Table 8C. Solid Sawn Timbers

Rating	1-HOUR				1.5-HOUR			2-HOUR		
	Beam Width	5.5	7.5	9.5	11.5	7.5	9.5	11.5	9.5	11.5
Beam Depth	Design Load Ratio, R _s									
5.5	0.34	0.51	0.61	0.68	0.09	0.12	0.14			
7.5	0.51	0.77	0.92	1.00	0.32	0.45	0.54	0.15	0.20	
9.5	0.61	0.92	1.00	1.00	0.45	0.64	0.76	0.32	0.43	
11.5	0.68	1.00	1.00	1.00	0.54	0.76	0.91	0.43	0.58	
13.5	0.72	1.00	1.00	1.00	0.60	0.85	1.00	0.51	0.68	
15.5	0.76	1.00	1.00	1.00	0.64	0.91	1.00	0.56	0.76	
17.5	0.78	1.00	1.00	1.00	0.68	0.96	1.00	0.61	0.82	
19.5	0.80	1.00	1.00	1.00	0.70	1.00	1.00	0.64	0.87	
21.5	0.82	1.00	1.00	1.00	0.73	1.00	1.00	0.67	0.91	
23.5	0.83	1.00	1.00	1.00	0.75	1.00	1.00	0.70	0.94	

Design Load Ratios for Exposed Timber Decks

(Structural Calculations at Standard Reference Conditions: C_D=1.0, C_M=1.0, C_t=1.0, C_i=1.0)

Table 9. Double and Single Tongue & Groove Decking

Rating	1-HOUR	1.5-HOUR	2-HOUR
Deck Thickness	Design Load Ratio, R _s		
2.5	0.22	-	-
3	0.46	0.08	-
3.5	0.67	0.23	0.03
4	0.86	0.40	0.12
4.5	1.00	0.56	0.25
5	1.00	0.71	0.38
5.5	1.00	0.85	0.51

Table 10. Butt-Joint Timber Decking

Rating	1-HOUR				1.5-HOUR			2-HOUR	
Beam Width	1.5	2.5	3.5	5.5	2.5	3.5	5.5	2.5	5.5
Beam Depth	Design Load Ratio, R _s								
2.5	0.05	0.12	0.15	0.18	-	-	-	-	-
3	0.09	0.24	0.30	0.36	0.03	0.04	0.05	-	-
3.5	0.14	0.35	0.44	0.53	0.08	0.12	0.16	-	-
4	0.18	0.45	0.57	0.68	0.14	0.21	0.28	0.02	0.08
4.5	0.21	0.54	0.68	0.80	0.19	0.30	0.39	0.04	0.16
5	0.24	0.61	0.77	0.92	0.24	0.38	0.50	0.06	0.24
5.5	0.27	0.68	0.85	1.00	0.29	0.45	0.59	0.09	0.32

American Forest & Paper Association

American Wood Council
1111 19th Street, N.W., Suite 800
Washington, DC 20036

America's Forest & Paper People[®]
Improving Tomorrow's Environment Today[®]

AF & PA[®]

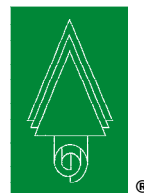

Revised January 2003