



Wood Stoves, Fireplace Inserts, and Chimneys

It is important to make sure that wood burning equipment is installed properly to prevent fires and injuries. That's why state law requires that a permit, inspection and approval be obtained from the Bureau of Development Services when installing a wood stove, fireplace wood stove insert or chimney in the City of Portland.

When permits are required

Project	Permit and Inspection	Fees
Installation of a wood stove, fireplace wood stove insert, wood furnace, pellet stove or any solid fuel burning appliance	mechanical	Minimum fee plus state surcharge
Installation of a factory built chimney or metal chimney	mechanical	
Construction or repair of a masonry fireplace and/or chimney	building	Based on the fair market valuation of the project
If stove or heat exchanger installation includes a fan and/or required electrical wiring	electrical required in addition to any other required permit	Based on the number of circuits affected by the work
Installation of a heat exchanger only, no fan or wiring necessary	none	

Wood stoves, inserts and wood burning appliances

Type	Comments	Installation
Listed and labeled wood stoves and fireplace wood stove inserts	Tested and approved by a recognized testing agency and are usually marked as listed by: <ul style="list-style-type: none"> • UL, Underwriters Laboratories • DEQ, Department of Environmental Quality • Warnock-Hershey 	According to the manufacturer's installation instructions which you should keep and show the inspector to verify correct installation
Certified wood stoves This includes listed and labeled, pellet, catalytic and noncatalytic, and fireplace inserts.	State Law (ORS 468.655) allows only wood stoves certified as new on or after July 1, 1986. These stoves cut down on air pollution and have a Department of Environmental Quality (DEQ) or Environmental Protection Agency (EPA) approved label.	If listed, then according to the manufacturer's instructions, otherwise according to International Mechanical Code (IMC)
Antique wood stoves Is your stove antique? Call the Residential Inspections Section at 503-823-7388.	<ul style="list-style-type: none"> • Built before 1940 • Of an ornate construction • Does not have to be certified 	According to International Mechanical Code (IMC)
Existing wood stoves Existing legal wood stoves are those that were legally installed before the new regulations and are exempt from the new regulations.	<ul style="list-style-type: none"> • A wood stove installed, inspected and approved with a mechanical permit before September 29, 1991 is legal. • The existing stove and the protection around it can be maintained. 	<ul style="list-style-type: none"> • Replacing or relocating the stove requires a permit, inspection and approval and it will no longer be allowed. • The stove must be either certified or antique to be inspected and legal.

Type	Comments	Installation
Catalytic wood stove	<ul style="list-style-type: none"> Has a catalytic combustor, allowing hazardous gases to burn at lower temperatures, and burns the smoke from the fire before it exits through the flue. The catalyst requires regular maintenance so that damage, or buildup does not occur. The catalytic cell may need to be replaced, this wear is normal. 	If listed and labeled, then according to the manufacturer's installation instructions, otherwise according to International Mechanical Code (IMC).
Noncatalytic wood stove	<ul style="list-style-type: none"> Burns gases through a hot firebox mixing the result with enough air to burn them entirely. This is secondary combustion. In new noncatalytic wood stoves, the usual combustion process is augmented by a second area of combustion that burns off the smoke before it exits through the flue. Follow the instructions for using the secondary air controls to maintain the clean and efficient operation of the stove. 	If listed and labeled, then according to the manufacturer's installation instructions, otherwise according to International Mechanical Code (IMC).
Fireplace inserts	<ul style="list-style-type: none"> A stove specially designed to fit into an existing masonry fireplace. More heat efficient than a regular fireplace and are easier to install than most wood stoves. May require more maintenance than most wood stoves to prevent creosote buildup in the chimney. 	<p>According to the manufacturer's installation instructions.</p> <p>Never install into a metal fireplace or into a fireplace with a metal fire chamber, unless both fireplace and insert are specially listed and labeled for that use.</p>
Pellet stove	<ul style="list-style-type: none"> Burns economical pellets made of recycled sawdust. Controls the fuel to air ratio within the stove ensuring almost complete combustion of the fuel, and generates minimal wood smoke. The EPA has labeled them the most efficient and environmentally safest of new wood stoves. 	If listed and labeled, then according to the manufacturer's installation instructions, otherwise according to International Mechanical Code (IMC and IRC).
Heat exchangers	<ul style="list-style-type: none"> Fit into existing fireplaces and most are constructed of tubing; they draw in air and send the heated air back into the room. Can be dangerous since some are made of thin metal that can burn through and those with poorly fitted joints can blow sparks, smoke or carbon monoxide directly into a room. May have a door that seals the front of the fireplace, making it almost airtight. This can cause very high temperatures in the damper area if there are weak spots in the fireplace and a fire at the mantle or in the wall could result. Check on the temperature of a combustible mantle after installation. If you can't comfortably keep the palm of your hand on the mantle for 30 to 60 seconds, then there is not enough clearance and the mantle must be protected. 	<p>According to the manufacturer's installation instructions.</p> <p>A fan requiring electrical wiring must be permitted and have an electrical inspection.</p>
Wood furnaces	<ul style="list-style-type: none"> Must be listed and labeled by an approved testing agency. Must be kept much farther from combustibles than other types of furnaces. 	According to the manufacturer's instructions.
Water heating Installing water heating coils, water jackets or similar devices in a wood stove can be hazardous. Discuss your plans before you buy or install such a water heating system by calling the Residential Inspection Section at 503-823-7388.		If the stove is listed and labeled for water heating, according to manufacturer's installation instructions.

Wall protection, wall spacers and combustible walls

Walls and ceilings are considered combustible if they contain any material that will burn. Even though a wall may be covered with brick or metal, without an air space between the wall protection and the combustible wall, heat can pass through the protection and into the wall. Eventually, wood inside the wall will break down and may catch fire at a relatively low temperature.

The side and rear of the stove must be positioned away from combustible walls

- According to manufacturer's specifications for listed and labeled stoves.
- Thirty six inches for an antique stove.
- Forty eight inches for unlisted stoves.

For a wood stove to be closer than the specified distance from a combustible wall, wall protection must be installed and acceptable wall shields include:

- Sheet metal, 24-gauge or heavier, spaced one inch from the wall with noncombustible spacers and ventilation along the top and bottom.
- Noncombustible insulating board, at least one-half inch thick, securely supported by a metal frame, ventilated along the top and bottom and spaced one inch from the wall.
- Brick wall, at least four inches thick, laid in front of a combustible wall, leaving a one inch air space between the two walls. The brick wall must have openings at the bottom and top for air to pass through.

Wall spacers are necessary to allow air space between the wall protection and the combustible wall.

- Make sure that all spacers, glue, plastic, covering and other materials used to create the air space are noncombustible and will retain their strength under intense heat.
- Square, rectangular or round metal tubing, conduit, pipe and channels make good spacers.
- Strips of sheetrock, plasterboard or asbestos should never be used.
- Spacers should be well attached to the wall framing. If this is not possible, call the Residential Inspection Division at 503-823-7388 for options on attaching spacers.

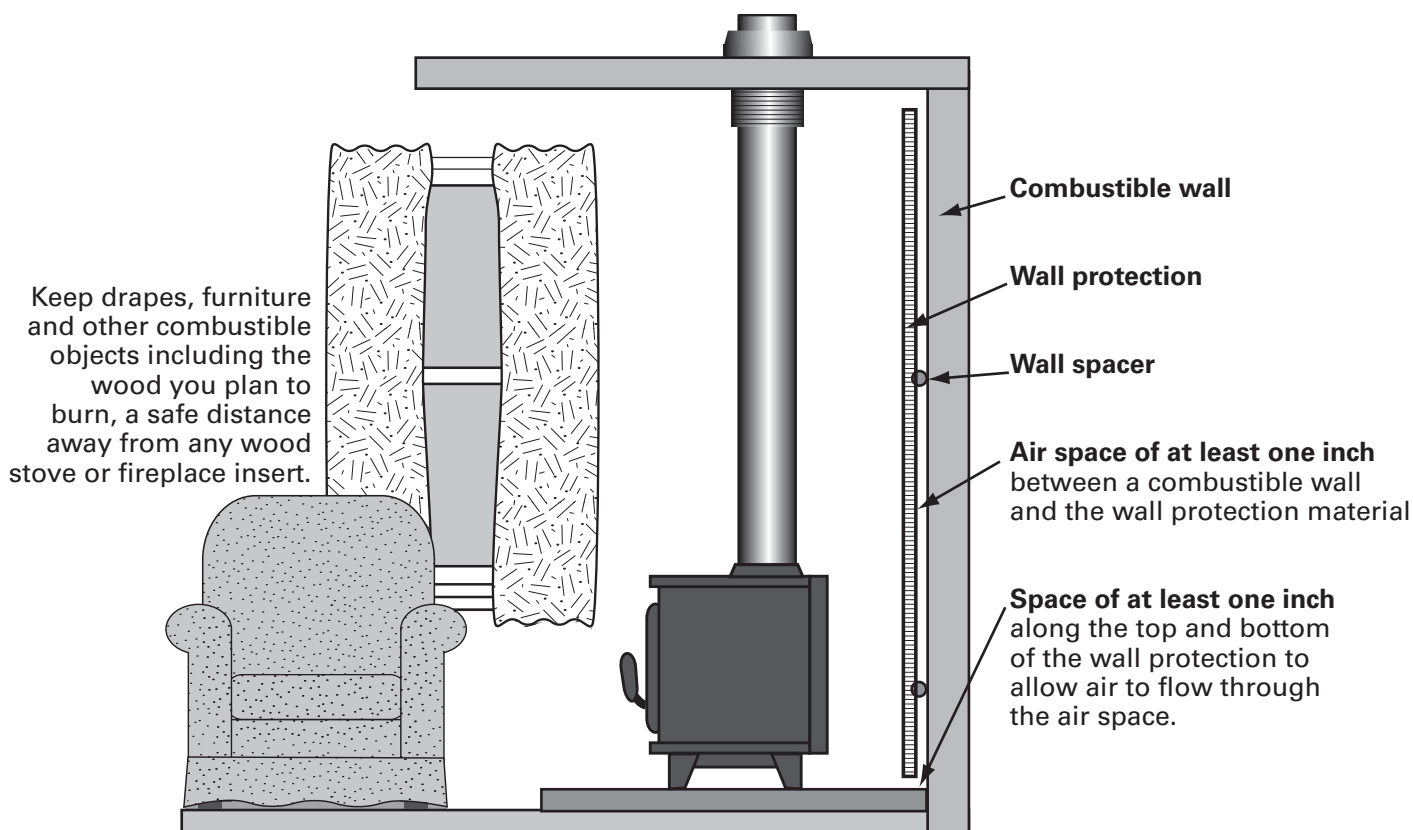

Chimney connectors and floor protection

The chimney connector is an important part of the heating system, and can be dangerous if not installed correctly.

- Choose chimney connectors that are listed and labeled for locations less than 18 inches from combustible construction. Otherwise, unlisted chimney connectors must be kept at least 18 inches from all unprotected combustible construction, including walls, ceilings, furniture, drapes, etc.
- Choose chimney connectors that are listed and labeled to pass through combustible construction, otherwise the connector must not pass through walls, floors or ceilings unless a listed and labeled wall pass-through device is installed for the connector to pass through.
- A wood stove can be connected to a lined masonry fireplace chimney as long as the damper is permanently sealed airtight. The damper must then be filled with sand, concrete or a similar fireproof material and the chimney connector installed above the damper.
- A chimney connected to a wood burning appliance must not be shared with or connected to appliances burning gas, oil, or other fuels. \

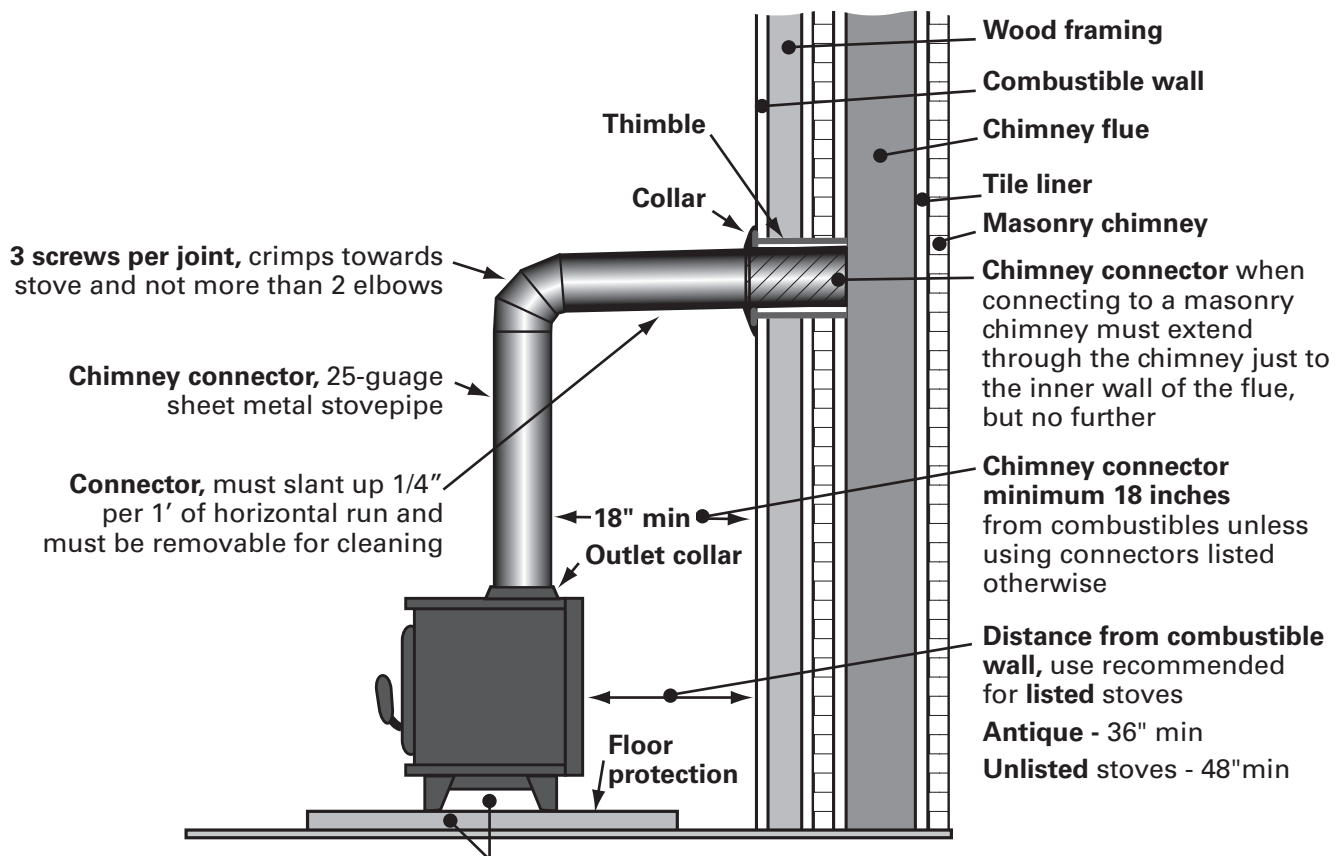

Floor protection for all stoves must extend at least 18 inches beyond the stove / insert on all sides, be noncombustible, and installed according to manufacturer's instructions.

Floor protection for antique and unlisted stoves must meet the above specifications and...

Stoves with at least 4 inches of open space between the stove and floor must have at least 3/8 inch thick insulating tile, brick, or other approved noncombustible material installed as floor protection and...

Stoves with less than 4 inches of open space between the stove and floor must be installed on hollow masonry units which must be:

- at least 4 inches thick and placed on the subfloor or finished floor
- laid with joints matched and ends open to provide circulation through them from side to side
- covered with sheet metal of at least 24-gauge US or other approved noncombustible material



Combustion air

For a fire to burn properly, a lot of air is required. In large rooms, air supply is usually not a problem. If you plan to install a stove in a small room, or if your house is particularly airtight, you must provide an air supply (combustion air).

- Combustion air must come directly from the outside. It may come through a duct and a grille that can be closed when there is no fire.
- The opening must be six and one-half inches minimum in area and located within 24 inches of the firebox.
- The air vent must not be located directly under the stove door because ashes could fall into it.

An inadequate air supply to your solid fuel appliance will cause incomplete burns, resulting in soot and smoke.

Fires that burn with sufficient air will consume the fuel and the released gases completely resulting in a cleaner fire with little or no smoke or soot.

Ventilation

- To reduce indoor air pollution, a good supply of fresh outdoor air is needed. The movement of air into and out of your home is very important. This supply of fresh air is also important to help carry pollutants up the chimney, stovepipe, or flue to the outside.
- Make sure that your vented appliance has the vent connected and that nothing is blocking it. Make sure there are no holes or cracks in the vent.
- Open the wood stove's damper when adding wood. This allows more air into the stove. More air helps the wood burn properly and prevents pollutants from being drawn back into the house instead of going up the chimney.

Location

- Locate your stove appropriately. Never install a stove in an alcove or closet unless the stove is specially listed for that location.
- Never operate a wood stove which has a vent outlet closer than 10 feet to a return air inlet for a forced air heating system.
- Keep combustible materials away from the wood stove.

Glossary

Certified wood stove - these stoves cut down on air pollution and have Department of Environmental Quality (DEQ) or Environmental Protection Agency (EPA) approved label. Any type of solid fuel burning stove may be certified, and to legally install a wood stove or fireplace insert it must be certified.

Chimney connector - is the stovepipe that connects the stove to the chimney. It must be a minimum of 24-gauge sheet metal and must be the same size as the outlet collar on the stove. Choose a chimney connector that is listed and labeled or keep the connector at least 18 inches from combustible construction.

Combustible materials - includes anything that can burn. Not only is the solid fuel (wood or wood pellets) combustible, but furniture, carpets, walls and floors can be combustible.

Connector pass-through - is the portion of the stove system that passes through the wall, and must be labeled for wall pass-through.

Floor protection - must be installed beneath a wood stove and must be of a noncombustible material, some wood stoves must be installed on a hollow masonry unit.

Flue collar, outlet collar - is the collar around the opening in the wood stove that connects to the chimney connector.

HT - high temperature

Manufacturers installation instructions - the instructions that come from the manufacturer to be used specifically for the installation of the particular wood stove they reference.

Thimble - can be metal or clay and must be permanently cemented to the chimney. Thimbles make for a tighter fit and allow removal of the connector for cleaning and inspection. Choose a listed and labeled thimble, or keep it 18 inches from combustible construction.

Wall protection - is a noncombustible shield installed between wall and stove with wall spacers to provide at least one inch of air space between the wall and the protection, and a gap of at least one inch at the top and bottom. Approved wall protection allows the wood stove to be installed closer to the wall.

Prefabricated Chimneys

The top of the chimney must be at least 2 feet higher than any part of the structure that is within 10 feet of the chimney and a minimum of 3 feet high measured from where it passes through the roof.

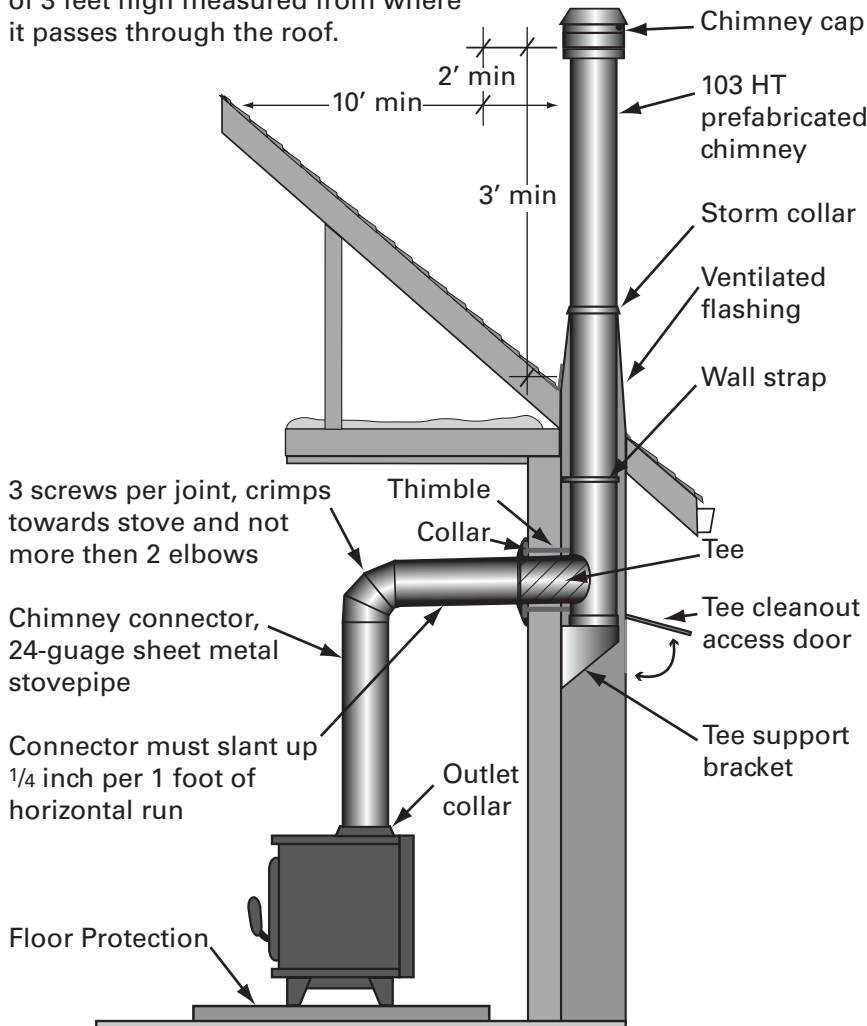

Use when the chimney goes through the outer wall and is enclosed and supported by a tee support bracket, maintain required clearance to combustible construction.

Use for a one story house with an attic, where the chimney is supported by the ceiling, maintain required clearance to combustible construction.



The same chimney to structure measurements apply to all chimney installations.

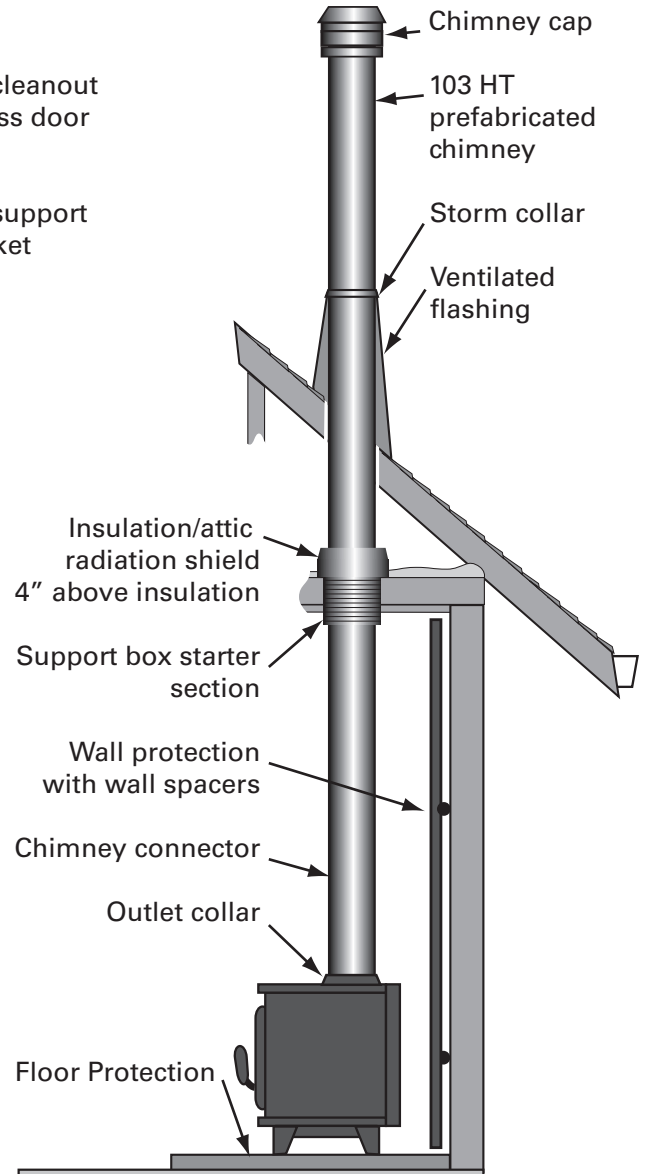

Chimneys

All wood stoves must be vented through a listed and labeled prefabricated metal chimney or a lined masonry chimney. A chimney connector, gas vent, single wall pipe or unlined masonry chimney cannot be used as a chimney for a wood stove.

- **Prefabricated Chimney Pipe** is approved factory built chimney pipe that has a label on each piece, which tells you that the chimney is type HT (high temperature). The label will also say how far you must keep the chimney pipe from combustible materials. All listed factory built chimneys must be Type HT and installed according to the manufacturer's installation instructions.
- **Existing Masonry Chimneys** should be inspected by a mason, chimney sweep or the homeowner before a wood stove connection is made. If the chimney is in bad shape, it must be repaired or taken down and a new one built. A building permit is required to construct a masonry chimney.
 - **To inspect the flue**, you can lower a drop cord down the chimney or use a flashlight and a mirror through the cleanout or thimble hole. Check the chimney for bad mortar, cracks, loose brick, broken or missing liners, blockages, unsealed openings and overall condition. If unsure, contact a professional.
 - **Old brick chimneys** are usually covered by construction, making it difficult to check for framing in contact with the masonry. Sometimes you can see whether there is space between the chimney and the wood construction by looking up around the chimney from the basement or crawl space. If you have any doubts about hidden areas around the chimney in contact with the construction, you should cut a hole in the wall to verify you have enough clearance. A clearance of two inches to all combustible construction is required.

Masonry Chimneys

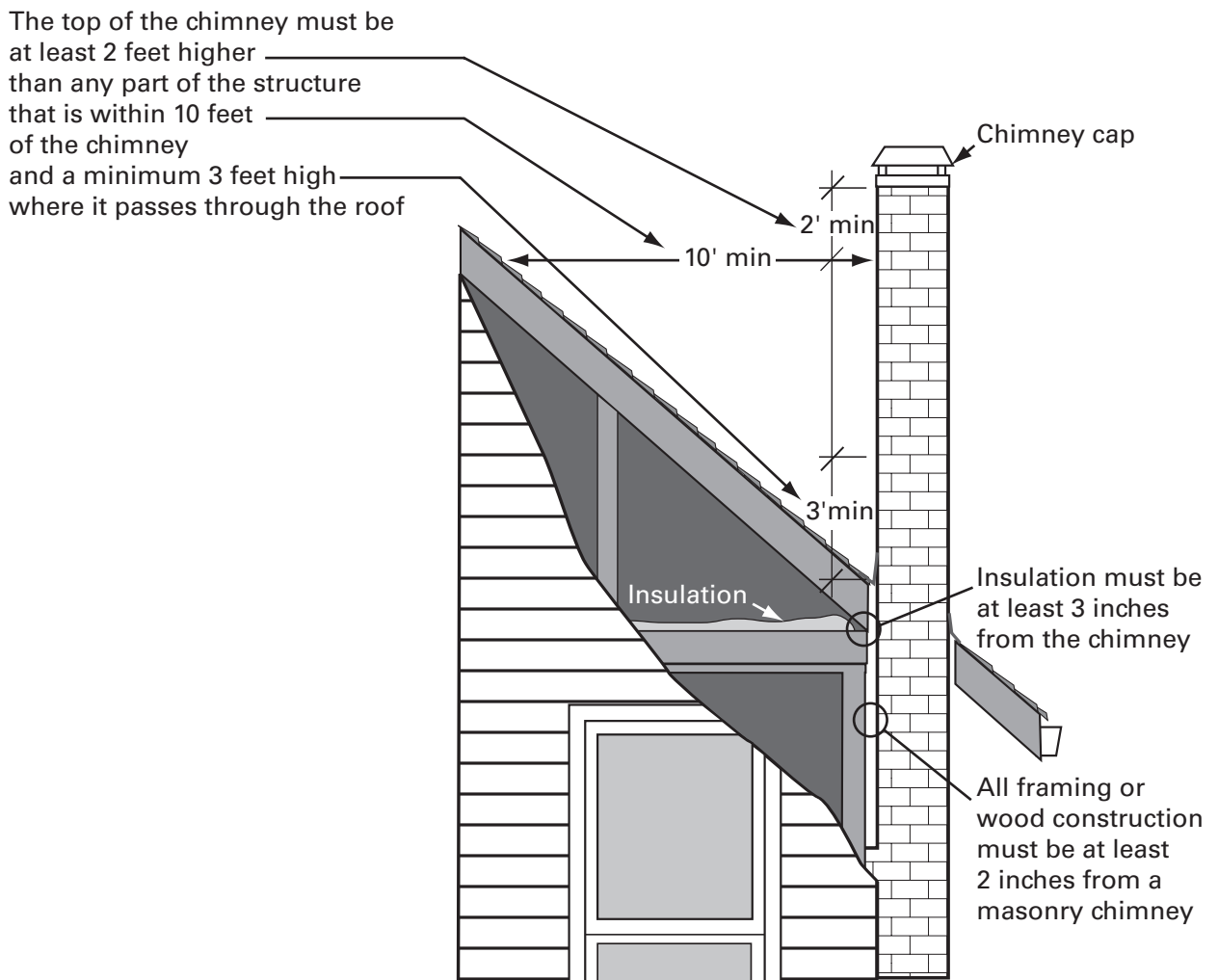

Certified wood stoves and the label

- **Certified wood stove** is one that has been tested and passed air pollution standards.
- **EPA** began certifying stoves in 1988. Newer approved stoves will carry an EPA label.
- **Oregon DEQ** certified wood stoves 1984 to 1988.
- **State Building Code** requires permits and inspections for wood stove installations, and allows the installation of only certified wood stoves.
- **Exceptions** may include pellet stoves, antique stoves, cook stoves, and wood burning furnaces. BDS can tell you if your wood burning appliance must be certified. A permit is always required for installation.

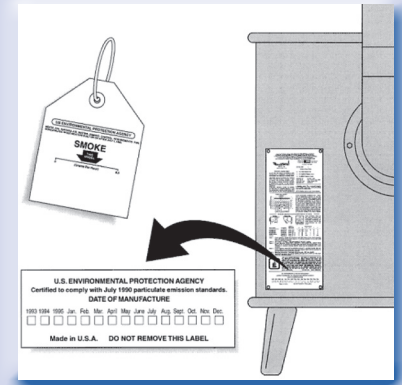

All certified stoves must have approval labeling from the EPA. Wood stoves often have several labels. A safety label lists requirements for safe clearances to walls, hearths, and chimneys and is often confused with **certification**. A safety label from a safety listing agency is NOT the same as EPA certification. It is very important to understand the difference when choosing a wood stove. EPA certified wood stoves will:

- Emit 50 to 60 percent less pollution.
- Use two-thirds less wood.
- Circulate heat more efficiently, so it stays in your home instead of going out the flue.
- Deposit less creosote buildup in chimneys.

Avoiding chimney fires

Creosote comes from burning wood without enough air for the fire, and it is a black, shiny tar like substance that can coat the inside of stoves, smoke pipes and chimneys. Even a half inch buildup can be dangerous. Creosote is what burns in the stove system during a chimney fire. Stoves and chimney connectors may become red hot in a chimney fire. Flaming embers may also blow out the top of the chimney and potentially cause a roof fire.

To help prevent creosote, burn the stove with the draft fully open at least once a day. The chimney and chimney connector must be cleaned with stiff wire chimney brushes and scrapers at least once a year. Some systems may need to be cleaned more often.

Scheduling an inspection

- Call 503-823-7000, the BDS 24-hour inspection request line
- Enter your IVR or permit number
- Enter the three-digit inspection code for the type of inspection you are requesting
- Enter a phone number where you can be reached during weekdays and if you want the inspection in the morning or afternoon
- There must be an adult over age 18 to let the inspector inside

Visit our Web site
www.portlandoregon.gov/bds

Helpful information

Bureau of Development Services

City of Portland, Oregon
 1900 SW 4th Avenue, Portland, OR 97201
www.portlandoregon.gov/bds

General Office Hours:

Monday through Friday, 8:00 am to 5:00 pm
 BDS main number: 503-823-7300

Permit Information is available at the following location:

Development Services Center (First Floor)
 For Hours Call 503-823-7310
 or visit www.portlandoregon.gov/bds

Permitting Services (Second Floor)
 For Hours Call 503-823-7310

or visit www.portlandoregon.gov/bds

Important telephone numbers

BDS main number	503-823-7300
DSC automated information line.....	503-823-7310
Building code information	503-823-1456
Zoning code information.....	503-823-7526
Permit information for electrical, mechanical, plumbing, sewer, and sign	503-823-7363
Permitting services	503-823-7357
Resource and records.....	503-823-7660
BDS 24-hour inspection request line requires IVR number and 3 digit type of inspection code	503-823-7000
For Information about Residential (1 & 2 family dwellings).....	503-823-7388
City of Portland TTY	503-823-6868

Note: All information in this brochure is subject to change.

res_woodstove 10/30/17