

- Construction Notes**
- 1 Install inlet protection - 2. See Std. Drg. No. RD1010.
  - 18 Remove inlet - 1. Plug lead.
  - 27 Adjust water facility.
  - 30 Construct concrete surfacing, 6" thick.
  - 32 Construct monolithic curb and sidewalk with 10" AC pavement repair. See Detail "A" on Sht. 2B.
  - 35 Construct monolithic curb and sidewalk with 16" AC pavement repair. See Detail "D" on Sht. 2B.
  - 45 Construct curb ending. See Std. Drg. No. P-540.
  - 48 Construct monolithic sidewalk ramp. See Sht. 2F-2. See Std. Drg. No. RD755.
  - 49 Construct Type C mountable island, 6" exposure. See Detail "C" on Sht. 2B and Std. Drg. No. RD705.
  - 52 Construct 16" AC pavement repair. See Detail "D" on Sht. 2B.
  - 53 Construct trench resurfacing. See Std. Drg. No. P-517.
  - 55 Construct 10" AC pavement repair. See Std. Drg. No. P-506.

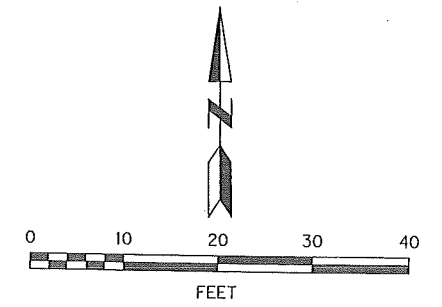

Plot Date: 4/21/2015 2:14:18 PM  
 File Name: S:\\_Design\T00419 - East Portland RFB Project\CAD\PLAN\_SHEETS\SHIT 07 STREET PLAN - SE STARK ST AT SE 151ST AVE\LOT\_SHT\_07.dgn

| NO. | DATE | DESCRIPTION | APPRO. |
|-----|------|-------------|--------|
|     |      |             |        |
|     |      |             |        |
|     |      |             |        |
|     |      |             |        |

|                                   |                                    |
|-----------------------------------|------------------------------------|
| DESIGNED BY<br><b>L. Williams</b> | DATE APPROVED<br><b>April 2015</b> |
| CAD BY<br><b>C. Shearer</b>       | DIV. ENGINEER<br><b>S. Townsen</b> |
| CHECKED BY<br><b>J. Joe</b>       |                                    |

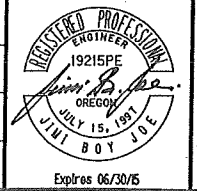

APPROVALS:

*Bob Appler*  
SUPERVISING ENGINEER REG. PROF. ENGR. NO. 14956PE

*Steve Townsen*  
CITY ENGINEER REG. PROF. ENGR. NO. 51539PE

**CITY OF PORTLAND**  
BUREAU OF TRANSPORTATION

STEVE NOVICK  
STEVE TOWNSEN, P.E.

COMMISSIONER  
CITY ENGINEER



East Portland Rapid Flash Beacon Project

**Street Plan**  
**S.E. Stark St.**  
**at S.E. 151st Ave.**

|             |            |
|-------------|------------|
| 1/4 SECTION | 3045, 3145 |
| PROJECT NO. | T00419     |
| SHEET NO.   | <b>7</b>   |