

Plot Date: 8/31/2016 9:42:52 AM Filename: U:\ustation\DCN\CITY OF PORTLAND - STANDARD DRAWINGS\SECTION DIVISIONS\3-STREETS\MICROSTATION STD DRAWING NO P-507\PLT_SHT_P-507.dgn

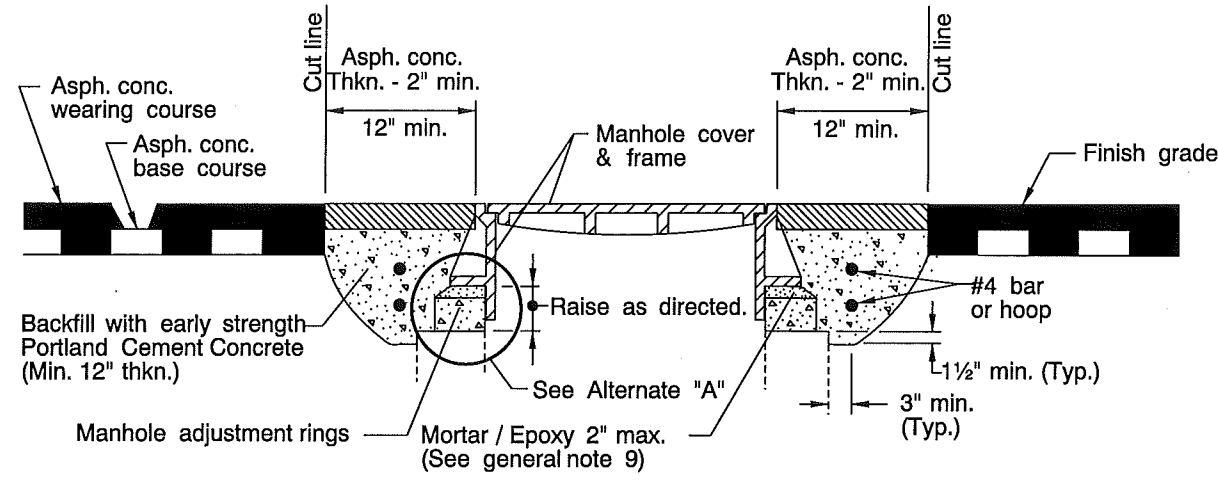

METHOD "A"

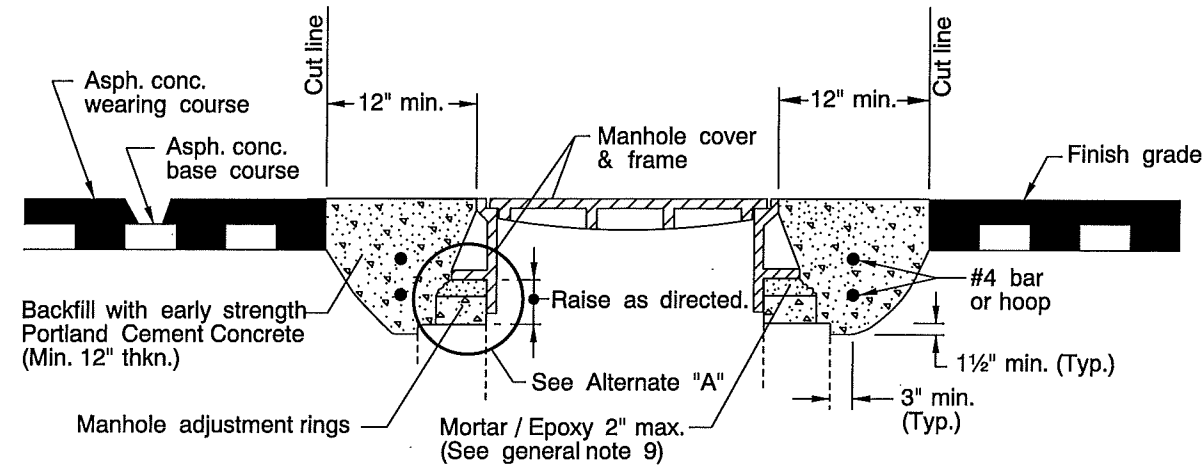

METHOD "B"

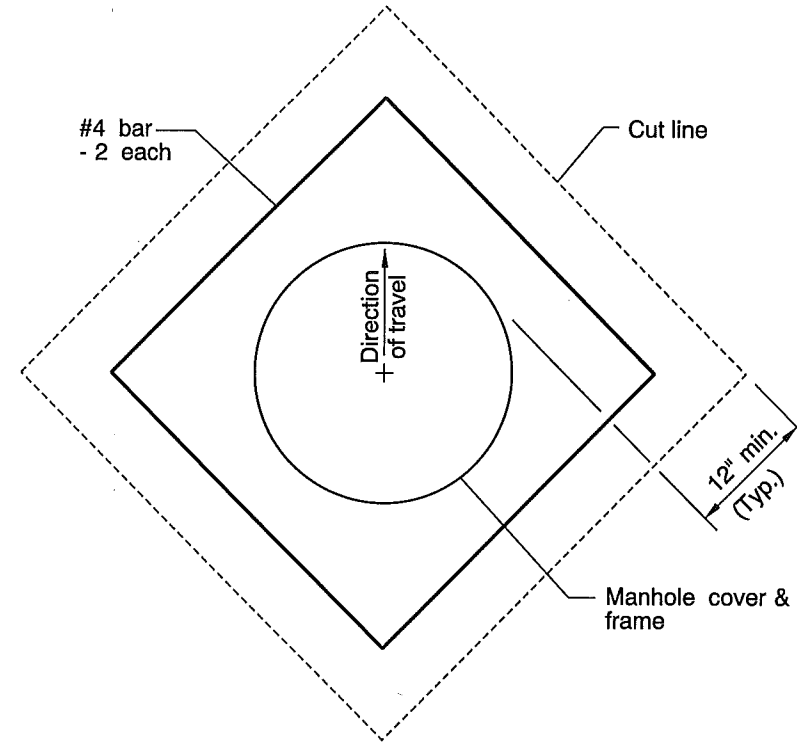

PLAN SQUARE CUT

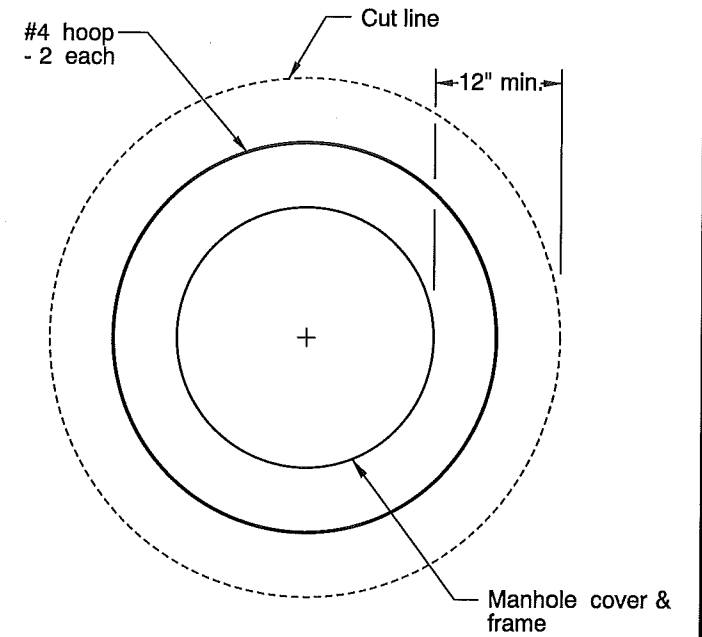

PLAN CIRCULAR CUT

GENERAL NOTES FOR ALL DETAILS:

1. Cover manhole with building paper and construct asphalt concrete base course and wearing courses.
2. Saw cut square or circular excavation around manhole 12" min. from manhole frame.
3. Raise manhole cover and frame and adjust to match finish grade by installing concrete manhole adjustment rings and leveling mortar, as shown.
4. Backfill with 4000 psi. minimum Portland Cement Concrete.
5. Protect from traffic loading.
6. Apply tack coat to edges of existing pavement before installing patch.
7. Sand seal all joints.
8. See P-171 thru P-182 for manhole covers and frames.
9. Use epoxy for synthetic grade rings.
10. Do not overcut beyond what is needed to achieve full depth cut.

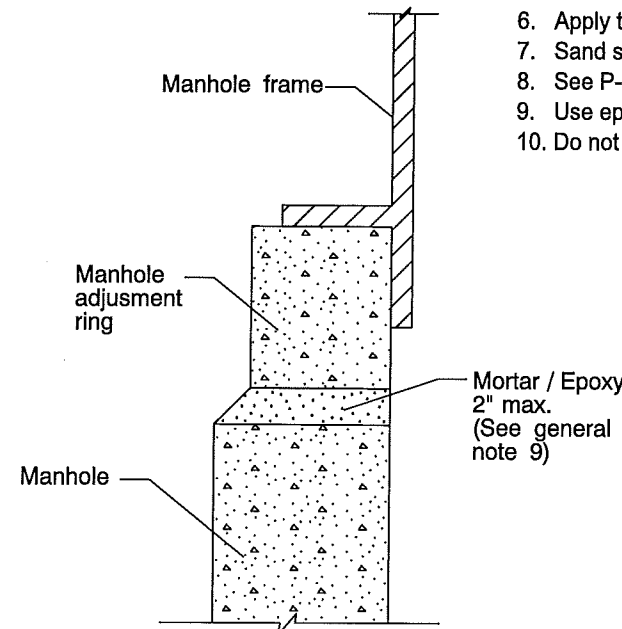

ALTERNATE "A"

The selection and use of this Standard Drawing, while designed in accordance with generally accepted engineering principles and practices, is the sole responsibility of the user.	PORTLAND BUREAU OF TRANSPORTATION City Engineer	
	Standard Drawing Title MANHOLE FRAME ADJUSTMENT	
Note: All material and workmanship shall be in accordance with the City of Portland Standard Construction Specifications.	Effective Date: 01-01-2017	Standard Drawing No. P-507
	Calc. Book No.: - Baseline Report Date: -	